

# Model-to-Text Requirements Engineering Using SysML Model-Based Structured Requirements Applied to Flight Control System Development

Presenter: **Michael Kellogg**  
Colorado State University / Woodward Inc.

Co-author: **Dr. Daniel R. Herber**  
Colorado State University

INCOSE International Symposium 2026  
June 16, 2026



# Systems Engineering

- A system is an arrangement of elements that together exhibit behavior or meaning that the individual elements do not exhibit on their own.
- Engineered systems are commonly organized into hierarchies.
- Systems engineering is an approach for developing, supporting, and retiring engineered systems.
- Successful systems engineering requires:
  - Developing a holistic understanding of the system.
  - Communicating clearly with stakeholders to share that understanding.
  - Comprehensive, bottoms-up verification that the developed solution satisfies the system needs.

Systems engineering mitigates the risk of developing solutions that are incorrect, too late, or too expensive for the stakeholders

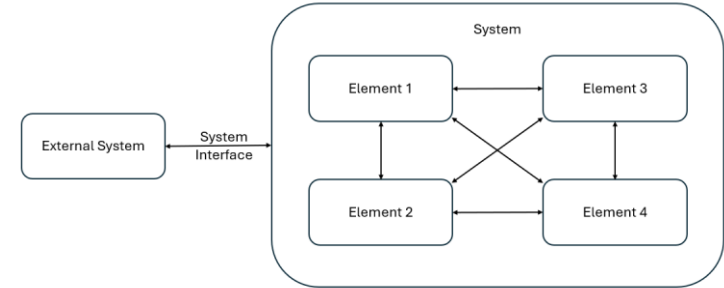

*Basic System.*

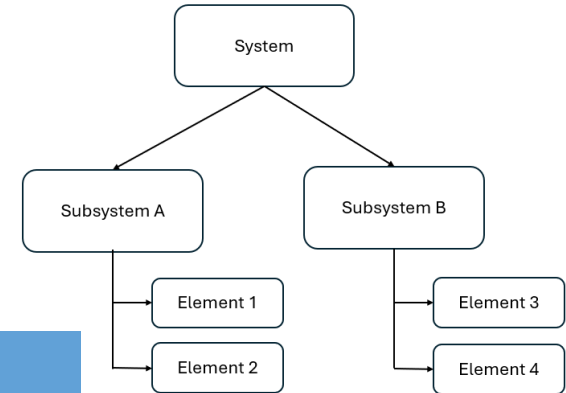

*Hierarchical System.*

# Requirements Engineering

- Requirements are a fundamental tool that systems engineers use to manage the complications and complexity of an emerging system.
- Requirements serve two purposes:
  - Provide a means for developing a shared understanding between stakeholders of what is required at each level of the system.
  - Provide a basis for determining the acceptability of a developed solution.
- Requirements are generated and organized into specifications at each level of the system hierarchy.
- **Requirement engineering is** the practice of:
  - **Generating** requirements.
    - Elicit, Write, Validate, Baseline
  - **Planning** requirement verification.
    - How, Where, by whom, to what criteria
  - **Managing** the validation and verification of the requirements.
    - Identify risks & remaining work

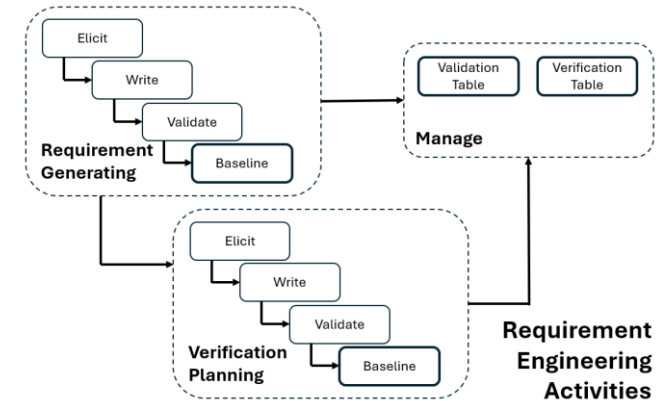
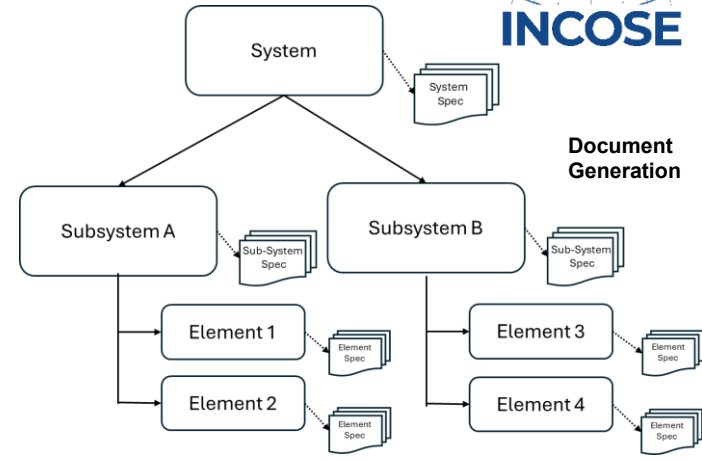

# Model-Based Systems Engineering (MBSE)

- Model-based design is replacing document-based design approaches.
  - Improved efficiency.
  - Improved capability to create complicated designs.
- Model-Based Systems Engineering (MBSE) approaches have been developed to gain the same benefits for system design.
- **MBSE principles:**
  - Includes a cross-discipline model as an authoritative source of truth.
  - Systems engineering documents originate in or are derived from that model.
- MBSE models include system elements, interactions, and behaviors.
  - Standardized modeling languages such as SysML.
  - Not intended to model geometry or performance simulation.
- MBSE Documents:
  - SysML models have diagrams to share information visually.
  - Modeling Tools come with report export capability.
  - CATIA Magic / Cameo products use VTL scripts for report generation.

# SysML Requirement Elements

- SysML has elements to supports the use of natural language requirements.
  - Requirement elements (attributes of ID, Name, Text)
- SysML supports establishing relationships between requirement elements and other model elements.
  - *Trace, Copy, DeriveReq, Verify, Refine, Satisfy, & Containment (global)*
- SysML supports customizations that allows users to add additional information & functionality.
- SysML requirement elements are meant to **serve as a bridge between a SysML model and the documentation.**

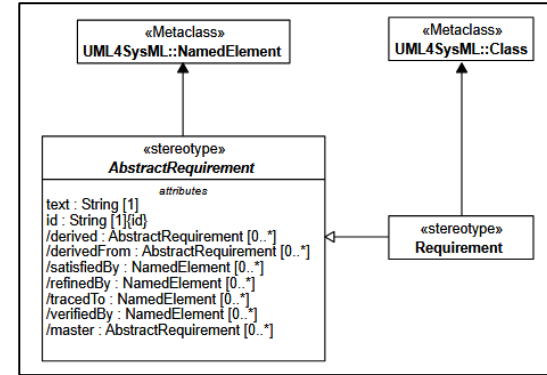

OMG SysML v1.17 [11] Figure 16.1

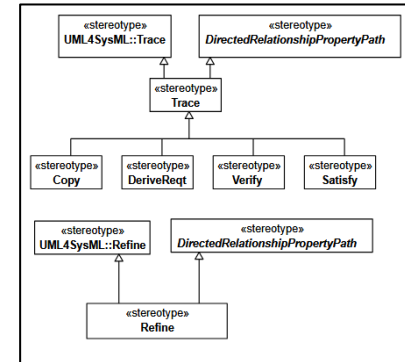

OMG SysML v1.17 [11] Figure 16.1

# MBSE Limitations

- MBSE enable systems engineers to develop complicated system models, but those models are not accessible to all stakeholders.
  - Not all stakeholder understand MBSE languages or have access to MBSE tools.
  - Specification of natural language requirements may be a foundational part of the stakeholder culture and processes resulting in significant friction and inertia for efforts to replace them.
- Bridging the gap
  - Subsystem natural language requirement specifications are still needed for stakeholder accessibility.
  - SysML requirement elements are the bridge linking the SysML model to the subsystem requirements.
- Limitations with requirement elements
  - Text is generated manually within the MBSE tool and must be manually updated if the model changes.
  - Like GD&T for mechanical drawings, there are rules that requirements must follow for clarity. However, the training and processes to ensure these rules are followed may not exist in an organization developing systems.
  - Translating from the model to text is time consuming, error prone, and low-value use of a valuable resource.

Subsystem requirements have accessibility challenges.

# MBSE Process for Hierarchical System Development

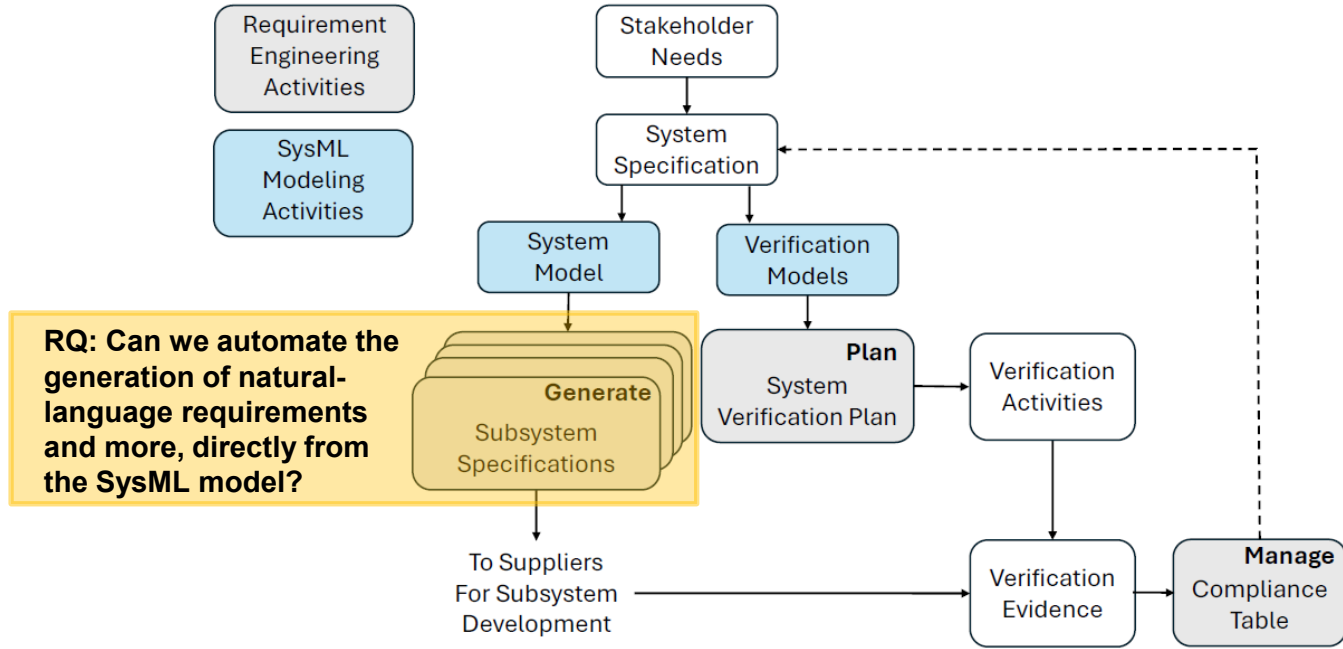

# Model-Based Structured Requirements

- Well formed requirements have defined structures.
  - Form 1 [Carson, 2015]: The **[who]** shall **[what]** **[how well]** under what **[condition]**
  - Form 2 [ISO 29148]: **[Condition]** **[Subject]** shall **[Action]** **[Object]** **[Constraint]**
  - The values used for each structural element often see reuse in a requirement set leading to these elements being referred to as boilerplates.
  - Standardizing on boilerplate structures and values can improve the quality and efficiency of requirement generation through improved reuse.
- Model Based Structured Requirements (MBSR) [Herber et. al., 2022]
  - **Associates system model elements with each of the requirement boilerplates.**
  - Similar to Property Based Requirements (PBR) which associates a constraint element with the **[constraint]** boilerplate.
  - Validate that the system model is in alignment with the system requirements.
  - Validate that the requirements are well formed.

# Constructing a Subsystem Model-Based Structured Requirement

- Unlike the system requirements, the requirement text attribute is not populated.
- Requirements are built by links to modeled boilerplate elements instead of writing text.

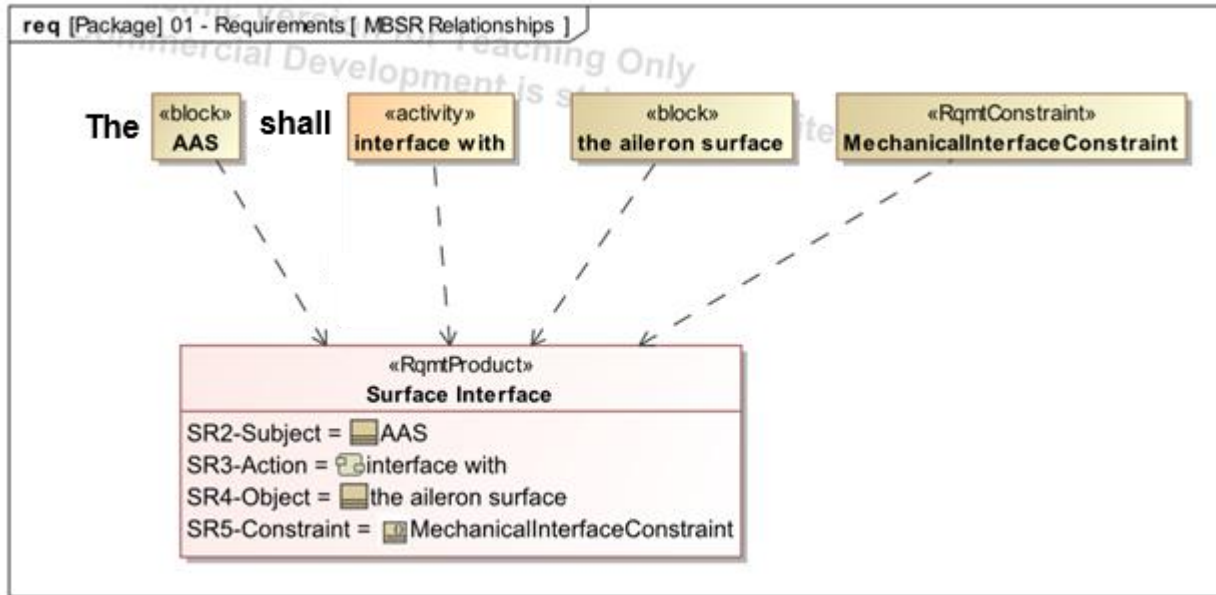

# SysML Customizations

- SysML customizations are needed for generating MBSR based documents.
- MBSR customization already publicly available in the MBSR\_ISO-INCOSE profile<sup>(1)</sup>.
- Customizations to support generating the documents.
  - Custom requirement elements,
  - Custom Relationship,
  - Custom Attributes.
- <<RqmtVerf>> Stereotype was created for elements which hold verification planning information.

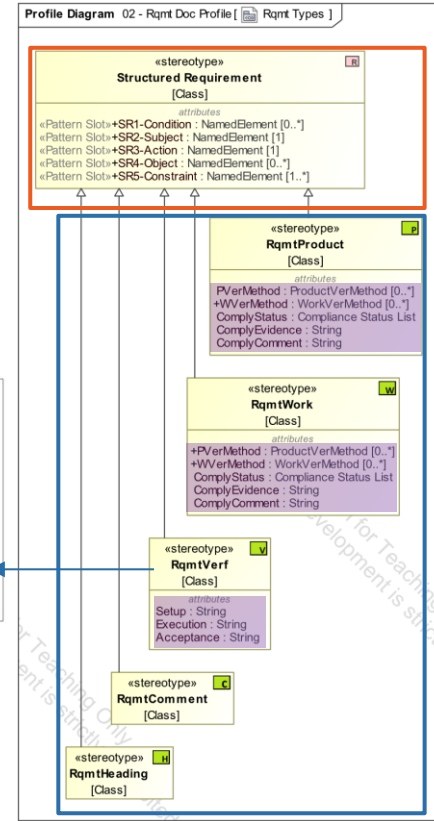
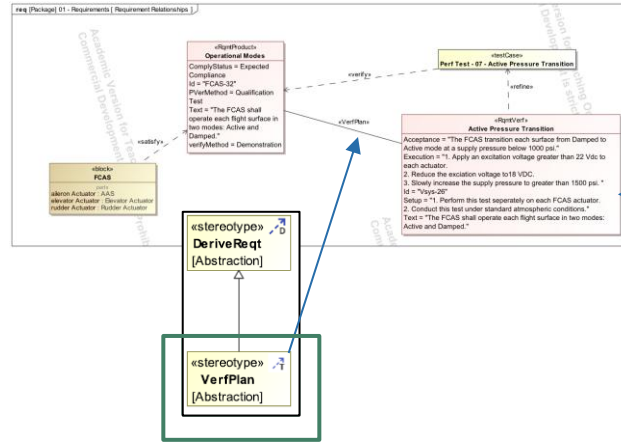

(1) <https://github.com/danielrherber/model-based-structured-requirements>

# VTL Script Customization

- We generated the requirements engineering documents using the Catia Magic / Cameo Report Wizard with customized Velocity Template Language (VTL) scripts.
- Velocity Template Language (VTL) scripts are used to give instructions for generating natural language documents from information in the model.
- The VTL scripts are saved as Microsoft \*.docx files. The VTL scripts control what information is exported from the model and the \*.docx files control how it is formatted.
- For a **standard requirement specifications**, the script exports the requirement text from the model.
- For **verification plans** it exports the verification attributes.
- For Subsystem MBSR Specifications the script exports the requirement's **MBSR attributes instead of the text attribute**.
  - **[Condition] [Subject] [Action] Object] [Constraint]**
  - **(Condition) [Subject] \*Action\* <Object> +Constraint+**

```
## Text Product Requirement output
#if ($Object.elementType == "rqmtproduct")
$Object.id    $Object.text
#end
## Text Work Requirement output
#if ($Object.elementType == "rqmtwork")
$Object.id    $Object.text
#end
```

```
## Verif Requirement output
#if ($Object.elementType == "rqmtverf")
#writeHeader($Object.Name)
$Object.id    Setup
                $Object.Setup
                Execution Instructions
                $Object.Execution
                Acceptance Criteria
                $Object.Acceptance
#end
```

```
## Structured Requirement output
#if ($Object.elementType == "rqmtproduct")
Subject.id    #if ($Object.SR1-Condition.size() > 0)#foreach ($from in $sorter.sort($Object.SR1-Condition, "Id"))When in $from.name the#end #else The #end#Subject.SR2-Subject.name shall $Object.SR3-Action.name#foreach ($from in $sorter.sort($Object.SR4-Object, "Id")) $from.name#end#foreach ($from in $sorter.sort($Object.SR5-Constraint, "Id"))$from.text#end.
#end
```

Color Coded MBSR Requirements

```
## Structured Requirement output
#if ($Object.elementType == "rqmtproduct")
$Object.id    #if ($Object.SR1-Condition.size() > 0) #foreach ($from in $sorter.sort($Object.SR1-Condition, "Id"))(When in $from.name) the#end #else The #end [$Object.SR2-Subject.name] shall *$Object.SR3-Action.name* #foreach ($from in $sorter.sort($Object.SR4-Object, "Id")) <$from.name> #end #foreach ($from in $sorter.sort($Object.SR5-Constraint, "Id"))+$from.text+ #end.
#end
```

Symbol Coded MBSR Requirements

# Case Study: FCAS

- Case Study for development of a Flight Control Actuation System (FCAS) and Aileron Actuation Subsystem (AAS).
- Generated system level requirements for a notional FCAS using guidance from SAE Standards [AIR4094, AIR4253B].
  - Wide range of requirement types including functional, operational, performance, environmental, business, and design constraints.
- Built SysML model of the FCAS.
- Generated MBSR requirements for the AAS.
- Generated verification plans.
- Generated preliminary compliance tables.

Documents originate from the model

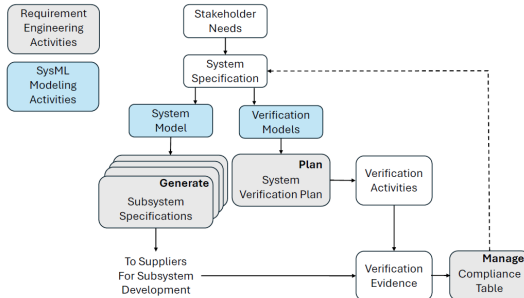
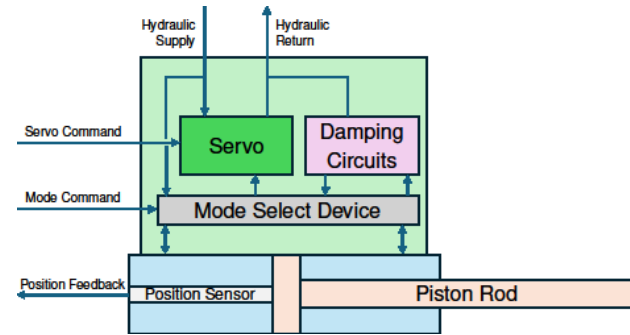
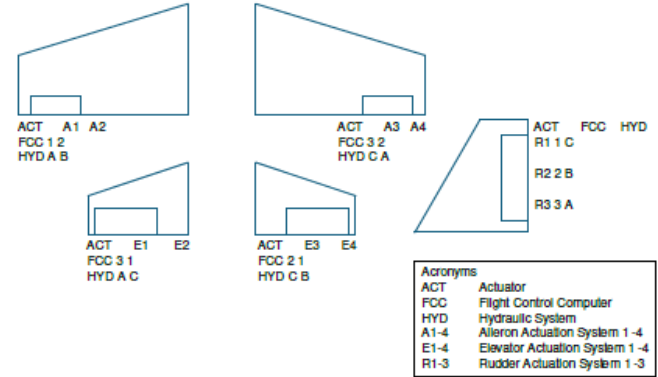

# Requirement Organization

- Set up requirement packages for the system and for each subsystem
  - System,
  - Subsystem.
- Packages were created at each level for the desired documents
  - Product (requirement specification),
  - Business (statement of work),
  - Verification (verification plan).
- Requirements for each document were added into the relevant package and organized using containment relationships by type.
- Requirement tables were added for working with the requirements within the MBSE tool.

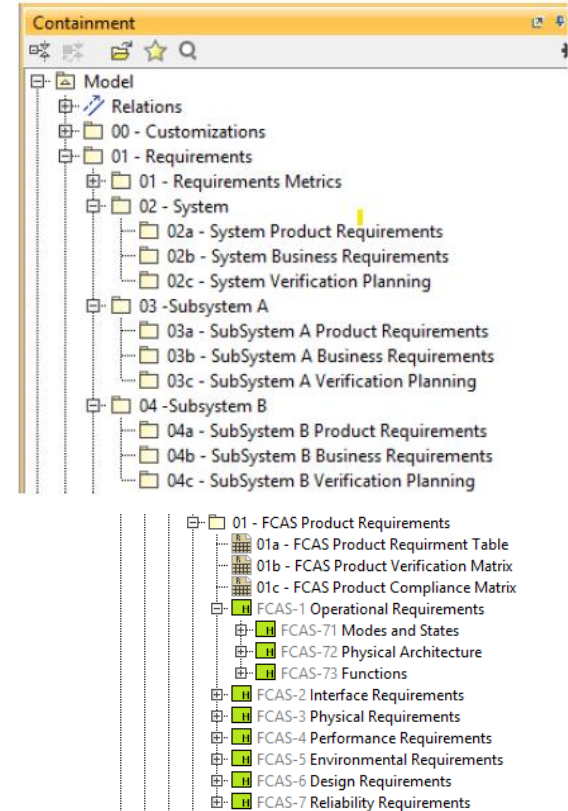

# Subsystem Product Requirements

- 31 product requirement blocks were created to hold 31 generated subsystem requirements.
- Requirement were stereotyped with the following new stereotypes:
  - <<RqmtProduct>>, <<RqmtHeading>>, <<RqmtComment>>.
- Requirements were organized with containment relationships by type.
- Each requirement was [linked to model elements to populated the relevant boilerplate elements](#).

#	Name	SR1- Condition	SR2- Subject	SR3- Action	SR4- Object	SR5- Constraint
1	AIL-1 Operational Requirements					
9	AIL-2 Interface Requirements					
19	AIL-3 Physical Requirements					
20	AIL-27 Weight		AAS	weigh		WeightConstraint1 WeightConstraint2
21	AIL-4 Performance Requirements					
22	AIL-28 Active Mode Travel					
23	AIL-38 Aileron Max Travel	Active Mode	AAS	move	the hydraulic piston	TravelConstraint
24	AIL-29 Active Operating Rate					
25	AIL-32 Aileron Operating Rate	Active Mode	AAS	move	the hydraulic piston	ActiveRateConstraint1 ActiveRateConstraint2 ActiveRateConstraint3
26	AIL-30 Damped Operation Rate					
27	AIL-39 Aileron Damped Rate	Damped Mode	AAS	move	the hydraulic piston	DampedRateConstraint1 DampedRateConstraint2
28	AIL-31 Mode Control					

# System Verification Plans

- 45 Verification plan blocks were created for capturing the information needed for the verification plan.
- Each plan was linked to at least one requirement with a <<VerPlan>> relationship.
- Each plan was linked to a test case.
- Each plan was populated with the information needed in a verification plan:
  - ID & Name,
  - Setup (Where),
  - Execution (How),
  - Acceptance (Criteria),
- Plans were organized with containment relationships.

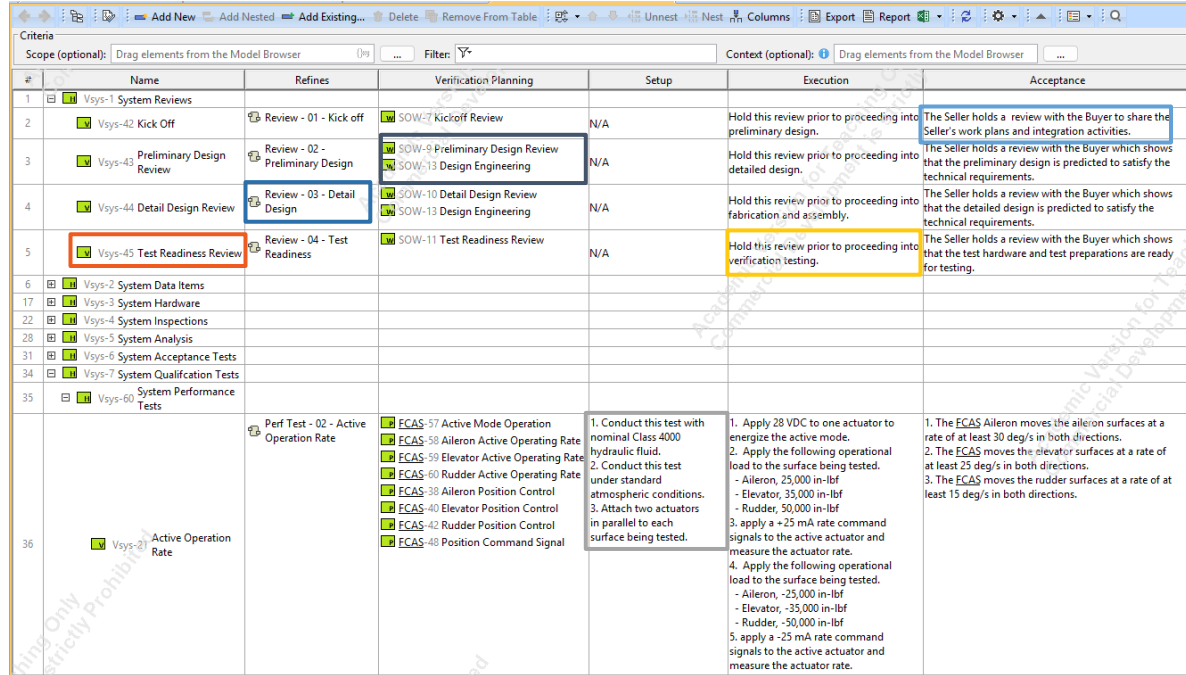

#	Name	Refines	Verification Planning	Setup	Execution	Acceptance
1	Vsysis-1 System Reviews					
2	Vsysis-42 Kick Off	Review - 01 - Kick off	SOW-7 Kickoff Review	N/A	Hold this review prior to proceeding into preliminary design.	The Seller holds a review with the Buyer to share the Seller's work plans and integration activities.
3	Vsysis-43 Preliminary Design Review	Review - 02 - Preliminary Design	SOW-9 Preliminary Design Review SOW-13 Design Engineering	N/A	Hold this review prior to proceeding into detailed design.	The Seller holds a review with the Buyer which shows that the preliminary design is predicted to satisfy the technical requirements.
4	Vsysis-44 Detail Design Review	Review - 03 - Detail Design	SOW-10 Detail Design Review SOW-13 Design Engineering	N/A	Hold this review prior to proceeding into fabrication and assembly.	The Seller holds a review with the Buyer which shows that the detailed design is predicted to satisfy the technical requirements.
5	Vsysis-45 Test Readiness Review	Review - 04 - Test Readiness	SOW-11 Test Readiness Review	N/A	Hold this review prior to proceeding into verification testing.	The Seller holds a review with the Buyer which shows that the test hardware and test preparations are ready for testing.
6	Vsysis-2 System Data Items					
17	Vsysis-3 System Hardware					
22	Vsysis-4 System Inspections					
28	Vsysis-5 System Analysis					
31	Vsysis-6 System Acceptance Tests					
34	Vsysis-7 System Qualification Tests					
35	Vsysis-60 System Performance Tests					
36	Vsysis-2 Active Operation Rate	Perf Test - 02 - Active Operation Rate	ECAS-57 Active Mode Operation ECAS-58 Aileron Active Operating Rate ECAS-59 Elevator Active Operating Rate ECAS-60 Rudder Active Operating Rate ECAS-38 Aileron Position Control ECAS-40 Elevator Position Control ECAS-42 Rudder Position Control ECAS-48 Position Command Signal	1. Conduct this test with nominal Class 4000 hydraulic fluid. 2. Conduct this test under standard atmospheric conditions. 3. Attach two actuators in parallel to each surface being tested.	1. Apply 28 VDC to one actuator to energize the active mode. 2. Apply the following operational load to the surface being tested. - Aileron, 25,000 in-lbf - Elevator, 35,000 in-lbf - Rudder, 50,000 in-lbf 3. apply a +25 mA rate command signals to the active actuator and measure the actuator rate. 4. Apply the following operational load to the surface being tested. - Aileron, -25,000 in-lbf - Elevator, -35,000 in-lbf - Rudder, -50,000 in-lbf 5. apply a -25 mA rate command signals to the active actuator and measure the actuator rate.	1. The ECAS Aileron moves the aileron surfaces at a rate of at least 30 deg/s in both directions. 2. The ECAS moves the elevator surfaces at a rate of at least 25 deg/s in both directions. 3. The ECAS moves the rudder surfaces at a rate of at least 15 deg/s in both directions.

# System Verification and Compliance Table

- The verification table shows the following for each requirements:
  - Required **verification method**,
  - Associated **verification plan**,
  - Associated **test case**.
- Compliance table shows the following for each requirements:
  - Required **verification method**,
  - Compliance **status**,
  - Compliance **Comment**,
  - Compliance **Evidence**.
- Verification Table is built from relationships, not text.
- Compliance Table is built from enumeration and text.
- Tables demonstrate alignment between the requirements and verification activities and identifies compliance risks.

#	Name	P Ver Method	Verification Planning	Verified By
3	FCAS-32 Operational Modes	Qualification Test	Vsys-26 Active Pressure Transition	Perf Test - 07 - Active Pressure Transition
5	FCAS-40 Elevator Position Control	Qualification Test	Vsys-21 Active Operation Rate	Perf Test - 01 - Mechanical Travel
6	FCAS-41 Elevator Mode Control	Qualification Test	Vsys-24 Active Transition Timing	Perf Test - 01 - Mechanical Travel
7	FCAS-42 Rudder Position Control	Qualification Test	Vsys-21 Active Operation Rate	Perf Test - 01 - Mechanical Travel
8	FCAS-39 Aileron Mode Control	Qualification Test	Vsys-24 Active Transition Timing	Perf Test - 01 - Mechanical Travel
9	FCAS-38 Aileron Position Control	Qualification Test	Vsys-21 Active Operation Rate	Perf Test - 01 - Mechanical Travel
10	FCAS-43 Rudder Mode Control	Qualification Test	Vsys-24 Active Transition Timing	Perf Test - 01 - Mechanical Travel
12	FCAS-33 Servo Controlled Actuators	Inspection	Vsys-31 Architecture	Inspection - 01 - Architecture
13	FCAS-34 Aileron Actuators	Inspection	Vsys-31 Architecture	Inspection - 01 - Architecture
14	FCAS-35 Elevator Actuators	Inspection	Vsys-31 Architecture	Inspection - 01 - Architecture

#	Name	P Ver Method	Comply Status	Comply Comment	Comply Evidence
3	FCAS-32 Operational Modes	Qualification Test	Expected Compliance		
5	FCAS-40 Elevator Position Control	Qualification Test	Expected Compliance		
6	FCAS-41 Elevator Mode Control	Qualification Test	Expected Compliance		
7	FCAS-42 Rudder Position Control	Qualification Test	Expected Compliance		
8	FCAS-39 Aileron Mode Control	Qualification Test	Expected Compliance		
9	FCAS-38 Aileron Position Control	Qualification Test	Expected Compliance		
10	FCAS-43 Rudder Mode Control	Qualification Test	Expected Compliance		

# VTL Exported Subsystem Requirement Specification

- Using VTL scripts executed by the Catia Magic / Cameo report wizard, the product requirements are exported to a word document.
- **Specification generated directly from the model, not written by the Systems Engineer.**
- The document is structured with key features of a specification:
  - Paragraphing,
  - Requirement identification numbers,
  - Generated requirement text,
  - Consistent formatting.
- Features:
  - Text generated from model elements,
  - Boilerplates are colored per the template,
  - Document structure mirrors the requirement table,
  - Commentary is not assigned an Identification number,
  - VTL script is saved as word doc, It can easily include other static information.
- Document only include the section exported from the model.

## 3. Requirements

### 3.1. Operational Requirements

#### 3.1.1. Mode and States

AIL-11 The AAS shall operate in Damped Mode Active Mode.

#### 3.1.2. Physical Architecture

AIL-12 The AAS shall contain the hydraulic piston the mode select valve the solenoid operated valve the electro-hydraulic servo valve the damping orifice.

#### 3.1.3. Functions

AIL-14 The AAS shall move the aileron surface.

AIL-15 The AAS shall transition between Damped Mode Active Mode.

### 3.2. Interface Requirements

#### 3.2.1. Mechanical Interface

AIL-19 The AAS shall interface with the aileron surface through a crank arm with a length of 3.5 inches.

#### 3.2.2. Hydraulic Interface

AIL-20 The AAS shall interface with the hydraulic system which conforms with AS 5440 Type II Class 4000.

#### 3.2.3. Electrical Interface

AIL-21 The AAS shall interface with a servo driver which produces a 25 mA rate command signal.

AIL-22 The AAS shall interface with a solenoid driver which produces a 28 VDC command signal which conforms with MIL-STD-704.

AIL-23 The AAS shall interface with a LVDT driver which produces an excitation voltage of 10 Vrms at 3000 Hz.

AIL-24 The AAS shall interface with a LVDT driver by producing an output signal with the following characteristics: Full Scale Output of +/- 0.5 V/V, Accuracy of +/- 1% F. S., Sum Voltage of 7.00 Vrms.

### 3.3. Physical Requirements

AIL-27 The AAS shall weigh less than 35 lbs when drained of hydraulic fluid.

### 3.4. Performance Requirements

#### 3.4.1. Active Mode Travel

AIL-38 When in Active Mode the AAS shall move the hydraulic piston over a total travel length of 3.5 inches.

# VTL Exported Subsystem Statement of Work

- Using VTL scripts executed by the Catia Magic / Cameo report wizard, the business requirements are exported to a word document.
- **Statement of Work generated directly from the model, not written by the Systems Engineer.**
- The document is structured with key features of a specification:
  - Paragraphing,
  - Requirement identification numbers,
  - Generated requirement text,
  - Consistent formatting.
- Features:
  - Text generated from model elements,
  - Boilerplates are identified with symbols,
  - Document structure mirrors the requirement table,
  - Commentary is not assigned an Identification number,
  - VTL script is saved as word doc, It can easily include other static information.
- Document only include the section exported from the model.

## 3. Requirements

### 3.1. Program Management

**SOW-38** The [AAS Supplier] shall "develop the" <AAS> + as defined in the contract+.

**SOW-39** The [AAS Supplier] shall "create" <a schedule> + with critical milestones and technical tasks+.

#### 3.1.1. Program Reviews

**SOW-42** The [AAS Supplier] shall "hold" <a kick off review> + with the Buyer to share the Seller's work plans and integration activities prior to proceeding into preliminary design+.

**SOW-43** The [AAS Supplier] shall "hold" <a preliminary design review> + with the Buyer to show that the preliminary design is predicted to satisfy the technical requirements prior to proceeding into detailed design+.

**SOW-44** The [AAS Supplier] shall "hold" <a critical design review> + with the Buyer to show that the detailed design is predicted to satisfy the technical requirements prior to proceeding into fabrication and assembly+.

**SOW-45** The [AAS Supplier] shall "hold" <a test readiness review> + with the Buyer to show that the test hardware and test preparations are ready prior to proceeding into verification testing+.

**SOW-41** The [AAS Supplier] shall "manage" <a risk register> + to identify and track development risks and their mitigation activities+.

### 3.2. Engineering

**SOW-46** The [AAS Supplier] shall "create" <a compliance matrix> + showing verification of the product to the requirements of the specification+.

**SOW-47** The [AAS Supplier] shall "create" <drawings> + as required to enable the manufacture of the product+.

#### 3.2.1. Analysis Engineering

**SOW-50** The [AAS Supplier] shall "analyze" <AAS> + to demonstrate that the product is expected to perform as required+.

**SOW-51** The [AAS Supplier] shall "analyze" <AAS> + to demonstrate that the product is expected to not be damaged by the thermal environments+.

**SOW-52** The [AAS Supplier] shall "analyze" <AAS> + to demonstrate the product is expected to satisfy the structural requirements+.

**SOW-53** The [AAS Supplier] shall "analyze" <AAS> + to demonstrate the product is expected to satisfy the reliability requirements+.

### 3.3. Assembly and Integration

**SOW-54** The [AAS Supplier] shall "fabricate" <prototype units> + as defined in the contract to be shipped to the Buyer+.

# VTL Exported System Verification Plan

- Using VTL scripts executed by the Catia Magic / Cameo report wizard, the verification plans are exported to a word document.
- **Plan generated directly from the model, not written by the Systems Engineer.**
- The document is structured with key features of a verification plan:
  - Paragraphing,
  - Requirement identification numbers,
  - Setup (Where),
  - Instructions (How),
  - Acceptance criteria (Criteria),
  - Consistent formatting,
- Features:
  - Export support embedded hyperlinks,
  - Commentary is not assigned an Identification number,
  - VTL script is saved as word doc, It can easily include other static information,
- Document only include the section exported from the model.

**3.5.2. Storage Life**  
**Vsys-30** **Setup**  
N/A  
**Execution Instructions**  
Analyze the FCAS for storage life.  
The FCAS will be stored in storage containers.  
**Acceptance Criteria**  
The FCAS has a storage life greater than 5 years.

**3.6. System Acceptance Tests**  
**3.6.1. Mechanical Travel**  
**Vsys-20** **Setup**  
1. Perform this test separately on each FCAS actuator.  
2. Conduct this test with nominal Class 4000 hydraulic fluid.  
3. Conduct this test under standard atmospheric conditions.  
**Execution Instructions**  
1. Command each actuator to the full retract position.  
2. Measure the position of the actuator and the output of the LVDT.  
3. Command each actuator to the full extend position.  
4. Measure the position of the actuator and the output of the LVDT.  
**Acceptance Criteria**  
When in Active mode, the FCAS shall move the aileron surfaces up to 60 degrees.  
When in Active mode, the FCAS shall move the elevator surfaces up to 50 degrees.  
When in Active mode, the FCAS shall move the rudder surfaces up to 90 degrees.  
The FCAS actuator LVDTs operate with an excitation of 10 Vrms at 3000 Hz.  
The FCAS actuator LVDTs have a Full Scale Output of +/- 0.5 V/V.  
The FCAS actuator LVDTs have an accuracy of +/- 1% F. S.  
The FCAS actuator LVDTs have a sum Voltage of 7.00 Vrms

**3.6.2. Weight**  
**Vsys-28** **Setup**  
1. Conduct this test on a benchtop separately for each FCAS component.  
2. Conduct this test under standard atmospheric conditions.  
3. Remove all hydraulic fluid from the test article.  
**Execution Instructions**  
1. Measure the weight of the unit on a calibrated scale.  
2. Sum the component weights to determine the shipset weight.  
**Acceptance Criteria**  
The FCAS shall have a dry weight that is less than 485 lbs.

**3.7. System Qualification Tests**  
**3.7.1. System Performance Tests**  
**3.7.1.1. Active Operation Rate**  
**Vsys-21** **Setup**  
1. Conduct this test with nominal Class 4000 hydraulic fluid.  
2. Conduct this test under standard atmospheric conditions.  
3. Attach two actuators in parallel to each surface being tested.  
**Execution Instructions**  
1. Apply 28 VDC to one actuator to energize the active mode.

# System Tables Exports

- Verification table and Compliance table are exported using the table export tool.
- No scripting or formatting required.
- Requirement exported as excel tables.

Name	P Ver Method	Verification Planning	Verified By	Applied Stereotype	Applied Stereotype
FCAS-32	Operational Modes	Qualification Test	Active Pressure Transition	Perf Test - 07 - Active Pressure Transition	RqmtProduct
FCAS-40	Elevator Position Control	Qualification Test	Active Operation Rate	Perf Test - 01 - Mechanical Travel	RqmtProduct
FCAS-41	Elevator Mode Control	Qualification Test	Active Transition Timing	Perf Test - 01 - Mechanical Travel	RqmtProduct
FCAS-42	Rudder Position Control	Qualification Test	Active Operation Rate	Perf Test - 01 - Mechanical Travel	RqmtProduct
FCAS-39	Aileron Mode Control	Qualification Test	Active Transition Timing	Perf Test - 01 - Mechanical Travel	RqmtProduct
FCAS-38	Aileron Position Control	Qualification Test	Active Operation Rate	Perf Test - 01 - Mechanical Travel	RqmtProduct
FCAS-43	Rudder Mode Control	Qualification Test	Active Transition Timing	Perf Test - 01 - Mechanical Travel	RqmtProduct
FCAS-33	Servo Controlled Actuators	Inspection	Architecture	Inspection - 01 - Architecture	RqmtProduct
FCAS-34	Aileron Actuators	Inspection	Architecture	Inspection - 01 - Architecture	RqmtProduct
FCAS-35	Elevator Actuators	Inspection	Architecture	Inspection - 01 - Architecture	RqmtProduct
FCAS-36	Rudder Actuators	Inspection	Architecture	Inspection - 01 - Architecture	RqmtProduct
FCAS-37	Actuator Modes	Inspection	Architecture	Inspection - 01 - Architecture	RqmtProduct
FCAS-47	Hydraulic systems	Qualification Test	Abnormal Pressure Hydraulic Interfaces	Inspection - 03 - Hydraulic interface Inter Test - 01 - Abnormal Pressure	RqmtProduct ElementReferenceInText
FCAS-44	Aileron Mechanical Interface	Inspection	Mechanical Interfaces	Inspection - 02 - Mechanical Interfaces	RqmtProduct
FCAS-45	Elevator Mechanical Interface	Inspection	Mechanical Interfaces	Inspection - 02 - Mechanical Interfaces	RqmtProduct
FCAS-46	Rudder Mechanical Interface	Inspection	Mechanical Interfaces	Inspection - 02 - Mechanical Interfaces	RqmtProduct
FCAS-48	Position Command Signal	Inspection	Electrical Interfaces Active Operation Rate	Inspection - 04 - Electrical Interfaces Perf Test - 02 - Active Operation Rate	RqmtProduct

# Benefits and Future Work

- Potential benefits from this method include:
  - 1) Ensuring alignment of subsystem natural language documentation with the model.
  - 2) Ensuring sub-system requirements consistently conform to the structured format.
  - 3) Reduced friction for MBSE adoption
  - 4) Time savings regarding writing and validating natural language requirements.
  
- Future work:
  - 1) Quantitative measurement of the identified potential benefits.
  - 2) Generation of metric reports for tracking requirement quality.
  - 3) Addition of determiner elements in the requirement structure for improved grammar.
  - 4) VTL alternatives for generating the requirement text.
  - 5) Incorporating LLM tools to improve efficiency and / or readability of the generated requirements.

# Thank you



# Questions?

**Model-to-Text Requirements Engineering Using  
SysML Model-Based Structured Requirements  
Applied to Flight Control System Development**

Paper # 425  
Michael Kellogg  
Dr. Daniel R. Herber



**Dr. Herber Research Group**