

# Software partitioning technique for an RF matching network on an embedded system.

As implemented on NetBurner Mod5270

Craig S. Powers  
Engineering  
Advanced Energy Inc.  
Fort Collins, CO 80526  
Craig.Powers@aei.com

**Abstract**— RF matching networks play a critical role in the semiconductor, flat-panel glass and DVD/Blu-ray industries to match the varying impedances of a plasma chamber to the industry-typical  $50\Omega$  source impedance of a RF generator for maximum power delivery. This paper will present a software partitioning scheme for building an L-topology [1] RF matching network. The software is targeted for a system using the NetBurner Mod5270 processor module. The ColdFire microprocessors offer key features such as a QSPI module to allow automatic A/D reading and buffering without microprocessor intervention, a GPIO module for interfacing to stepper motors control chips, and Programmable Interrupt Timers to allow precise stepper motor timing and movement.

**Keywords**-component; Match, network, RF, Stepper motor

## I. INTRODUCTION

During the manufacturing of silicon wafers used in making IC chips and solar cells, RF is used to generate plasma in a vacuum chamber to etch and deposit doped layers used to build up the structures of silicon wafers. RF plasma is also used in the DVD and CD coatings and glass coating processes. A plasma chamber's complex impedance varies depending upon the types of gases used, such as argon, silane, and hydrogen, and the gas pressure in the chamber. Any change in the plasma impedance is reflected back to the input of the matching network, so the network must compensate by adjusting a series or shunt capacitor in the L-network match to maintain the ideal  $50\Omega$  load to the RF generator. Industry typical RF generators are designed to deliver their maximum RF power into a  $50\Omega$  load and their output power will be reduced as the reflection coefficient  $\Gamma$  of the load increases from zero to one. The typical power delivery profile of a RF generator looks like a cropped mountain centered on  $50+j0\Omega$  when projected in 3D on a complex plane as shown in Fig. 1. The RF generator's ability to deliver power drops as the load impedance moves away from the ideal  $50+j0\Omega$ . If the power delivered to the plasma drops during a chip manufacturing step, the whole wafer could be scrapped. It is the job of a RF matching network to provide active impedance matching [2] between a RF generator and the complex plasma impedance to always maximize RF power delivery.

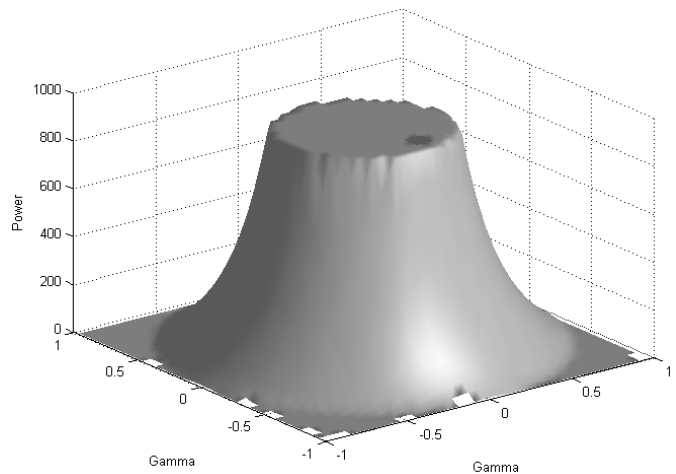

Figure 1. Ideal power delivery profile for RF generator with  $50\Omega$  source impedance

### A. L-match topology

Fig. 2 shows a RF matching network as it is connected up to a RF generator and Plasma chamber. Status monitoring and match control interfaces such as Ethernet and RS-232 can also be connected to an external computer but are not necessary in the simplest implementations. Within the matching network there is an RF input sensor connected to an embedded microprocessor. The RF from the RF generator flows through the RF input sensor to a network of inductors and capacitors in the shape of the letter 'L'. Making a single element variable in this network will provide an arc of tunable load impedances that the match can tune to provide a  $50\Omega$  load to the RF generator. To achieve two degrees of impedance matching for covering a tunable area of load impedances, one series and one shunt element are chosen to be variable. Because of their high reliability, consistent series resistance, and high current and voltage capability, vacuum variable capacitors are typically favored over variable inductor elements.

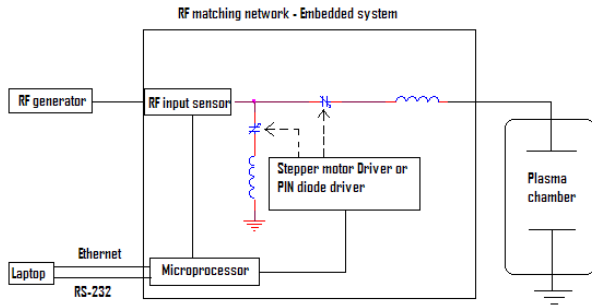

Figure 2. Typical L-match RF matching network configuration.

### B. Tunable Load range of a L-network match

Fig. 3 shows the typical plasma load tune range for an L-topology RF matching network when both the series and shunt elements are varied across their full range.

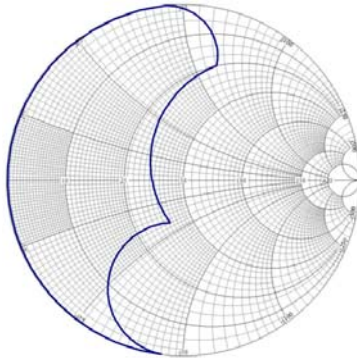

Figure 3. Area of load impedances for a typical L-match

### C. Measuring the load range of a L-network

The tunable load range of a RF match can be measured and mapped by connecting a 50Ω load where the RF generator is usually connected, and a network analyzer where the plasma chamber is normally connected, as shown in Fig. 4.

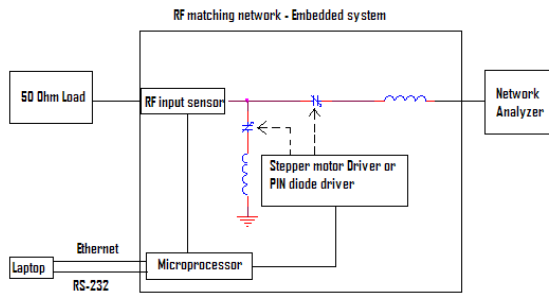

Figure 4. Measuring the load range of a match

## II. SYSTEM COMPONENTS

### A. Input Sensor

The RF sensor can either be a directional coupler or a Voltage Current sensor. A directional coupler samples the RF signal and will return an attenuated sample of both the forward

and reflected RF signal. The forward and reflected samples can then be processed in a variety of manners to provide a magnitude and phase signals to use as error signals to drive the variable capacitors until the RF sensor sees a 50Ω load looking into the matching network.

A Voltage Current (VI) sensor uses a capacitive pickup to provide an attenuated voltage signal of the input RF and an inductive pickup to provide an attenuated current signal of the input RF. A real power signal can be derived by multiplying the voltage signal times the current signal times the cosine of the phase angle difference of the voltage and current signal. The reactive power component can be derived by multiplying the voltage signal times the voltage signal times the sine of the phase angle difference of the voltage and current signal. These signals are high frequency and must be multiplied using fast hardware multipliers. Near a short on the Smith© chart, the voltage approaches zero; near an open, the current approaches zero. Since the real and reactive signals are products of the current and voltage, additional signals are used such as current squared or voltage squared to cover the boundary conditions of a near short or near open on a Smith© chart. Using these signals, computations can be made to compute Power, R, X, V or I, or other derivatives such as VSWR and Γ.

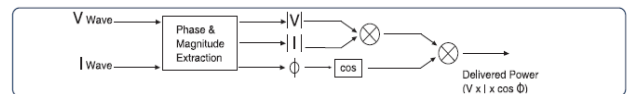

Figure 5 - Calculating Delivered Power

A circuit was constructed to interface an Advanced Energy 3X RF input sensor to the NetBurner Mod5270 development board. The 3X sensor utilizes a VI pickup and processing circuitry to produce real, reactive and I-squared signals. These signals are fed into an 8-Channel 12-bit TLV2548 A/D converter with an SPI bus interface. The NetBurner Mod5270 is based upon 3.3V while the RF input sensor runs at 5V. A 74LCX04 (5V input fault tolerant) chip was used to convert the 5V Data Out SPI line of the TLV2548 A/D to a 3.3 V signal for the input to the NetBurner's SPI bus input. Even though the RF input sensor's TLV2548 A/D chip's Vcc is 5V, its spec sheet states the input voltage high minimum is met with a 3.3V High. Therefore, no conversion from 3.3V to 5V was necessary from the NetBurner's outputs to the inputs of the TLV2548 A/D chip.

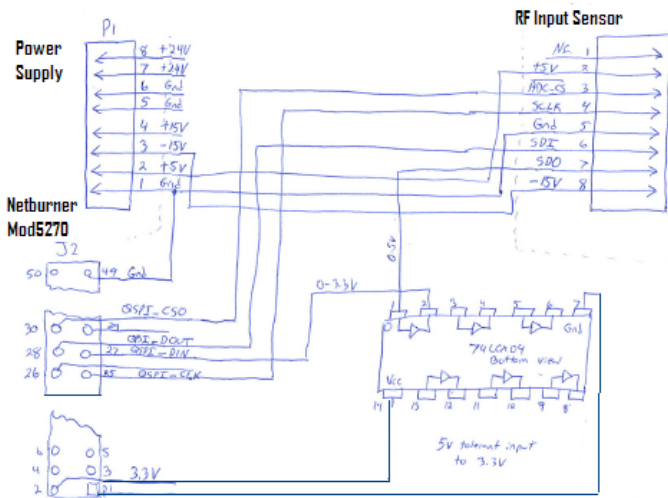

Figure 6. Circuit to interface NetBurner Mod5270 to RF input sensor

### B. Stepper motors

Steppers come with 2 or 5 phase coils and can be driven in many different modes such as full, half and microstepping mode. An interface from the NetBurner Mod5270 to an Advanced Energy stepper motor board was designed utilizing the available NetBurner GPIO pins (see Fig. 7). The stepper motor board utilizes two of the Allegro SLA 7026 3A PWM Uni-polar stepper motor chips.

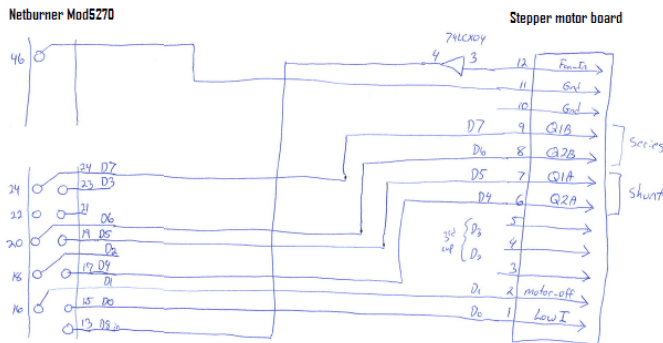

Figure 7. Interface from NetBurner Mod5270 to stepper motor drive board

For maximum torque to drive the vacuum capacitors, phase A and phase B of the steppers were driven in the full step mode as shown in the blue region of Fig. 8.

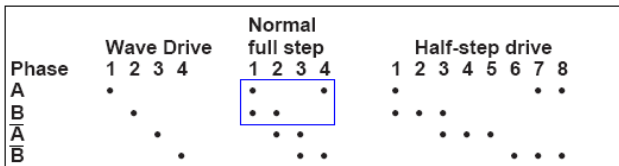

Figure 8. Stepper motor excitation sequences for different drive modes

A programmable interrupt timer [5] was used to drive the stepper motors more quickly than was possible using the NetBurner's uCOS alone. The interrupt service routine would move the stepper motors one step in the appropriate direction at each interrupt, if the motor had not yet reached the desired position.

When the step rate was changed from 250Hz to 1000Hz, the stepper motors would occasionally stop moving and would instead vibrate back and forth, apparently because the maximum start rate of the stepper motors was exceeded. A typical stepper motor curve is shown in Fig. 11. If a simplistic acceleration routine were added to the interrupt service routine to allow missing every other step for the first couple of steps, the speed could be further increased.

### C. NetBurner Mod5270

The NetBurner Mod5270 module offers the following features:

- 10/100 Ethernet Port RJ-45 with integrated magnetics and LED's
- 32-bit ColdFire 5270 processor with integrated Ethernet
- 141 Dhrystone 2.1 MIPS at 147.5MHz
- Two 50-pin interface connectors
- Address bus
- 16-Bit External Data bus
- 3 UARTs
- Chip selects
- Interrupts
- 47 Digital I/O
- Four 32-bit Timers
- Four Programmable Interrupt Timers
- Four Channel DMA
- Watchdog
- I2C
- QSPI
- 512k of Flash Memory
- 2MBytes SDRAM
- 64k Internal SRAM
- 8k Instruction/Data cache
- MAC module (32x32) hardware divide

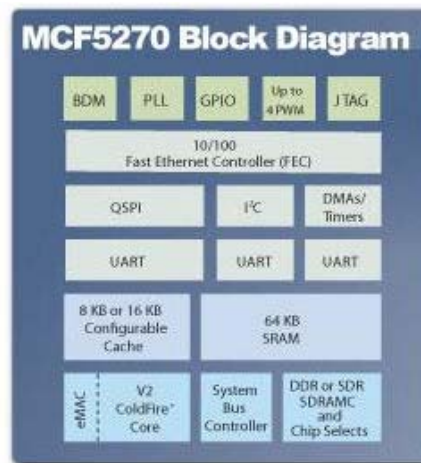

Figure 9. ColdFire MCF5270 Block Diagram

### III. SOFTWARE ARCHITECTURE

A sequential program model was drawn up to show the minimalistic behavior of a RF matching network.

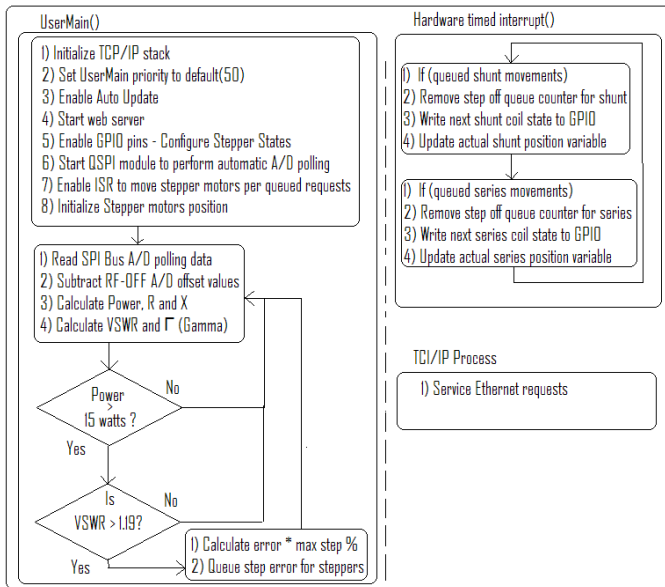

Figure 10. Program State Model for RF matching network

#### IV. FUTURE IMPROVEMENTS

Suggested improvements to the match design would be to replace the stepper motor driver with a microstepping version of the stepper motor chip (such as the Allegro SLA7062) to allow trade-offs in match resolution versus tuning speed. An RS-232/Ethernet command handler thread could be implemented to allow querying of match status and remote control. Improved stepper motor acceleration [6] could be implemented using a ColdFire 5234 microprocessor instead of the ColdFire 5270, as the ColdFire 5234 has an ETPU module embedded within it which allows table lookups for improved motion control.

#### V. CONCLUSION

The equipment and software as used is more than sufficient to implement a stepper motor stepping at 250Hz (and probably up to 500Hz or so). Minor software-only improvements could easily improve the rate of stepping to well over 1000Hz.

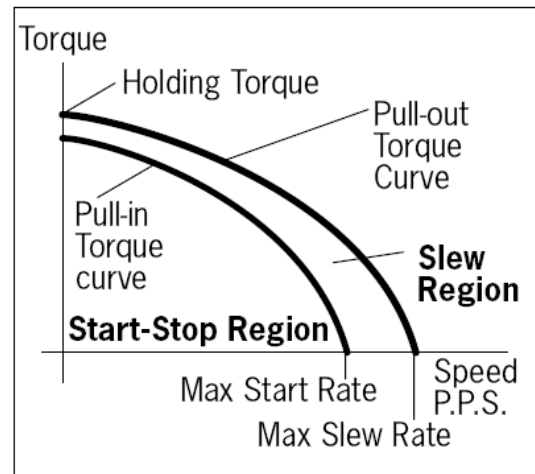

*Torque vs. speed characteristics of a stepper motor.*

Figure 11 -Typical maximum start rate curve for stepper motors

#### REFERENCES

- [1] Advanced Energy Industries, "Impedance Matching", unpublished. [http://www.advanced-energy.com/upload/File/White\\_Papers/ENG-WHITE18-270-02.pdf](http://www.advanced-energy.com/upload/File/White_Papers/ENG-WHITE18-270-02.pdf)
- [2] Advanced Energy Industries, "Tuner Topics", unpublished. [http://www.advanced-energy.com/upload/File/White\\_Papers/ENG-WHITE16-270-02.pdf](http://www.advanced-energy.com/upload/File/White_Papers/ENG-WHITE16-270-02.pdf)
- [3] "Mod5270-HardwareDesignNotes", Application Note by NetBurner, unpublished.
- [4] "Mod5270 Platform Reference", by NetBurner, unpublished.
- [5] "Mod5270 Programmable Interrupt Timer", Application Note by NetBurner, unpublished.
- [6] "Mod5234 ETPU for improved stepper motor control - TPUPN04.pdf", unpublished. [www.freescale.com](http://www.freescale.com)
- [7] "Stepper Motor Basics", Industrial Circuit Application Note, unpublished.