

CARTESIAN COORDINATES

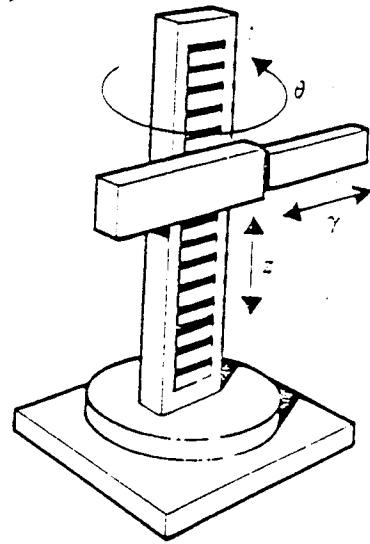

CYLINDRICAL COORDINATES

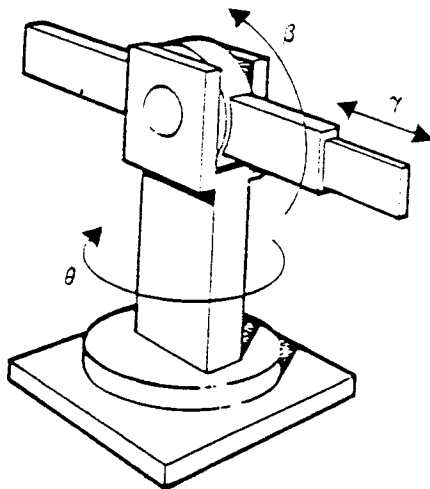

(SPHERICAL)  
POLAR COORDINATES

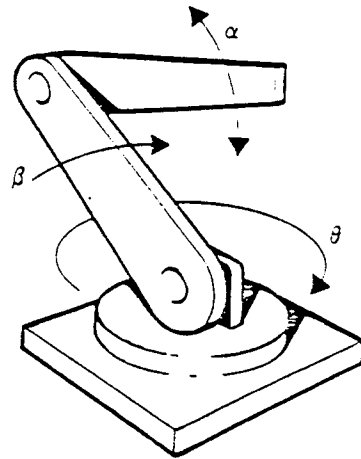

(JOINTED)  
REVOLUTE COORDINATES

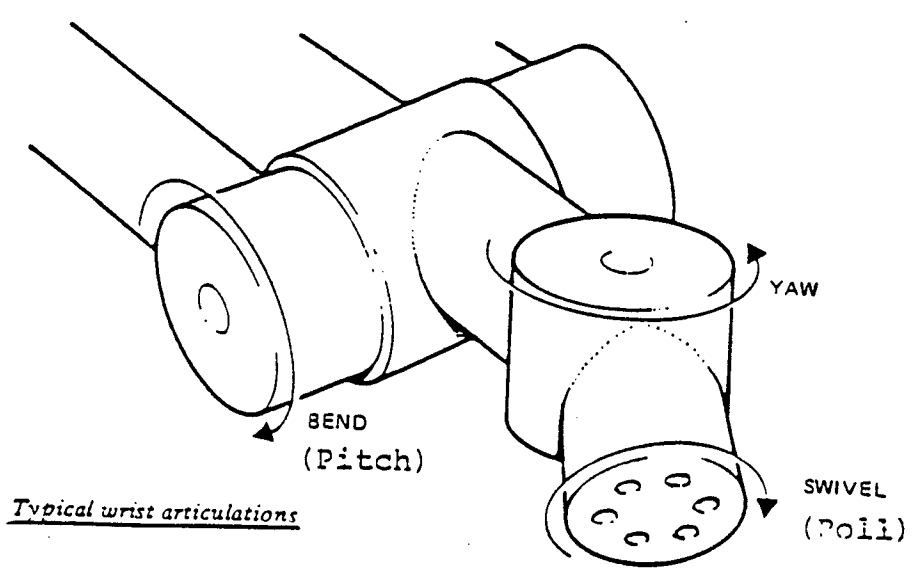

Typical wrist articulations

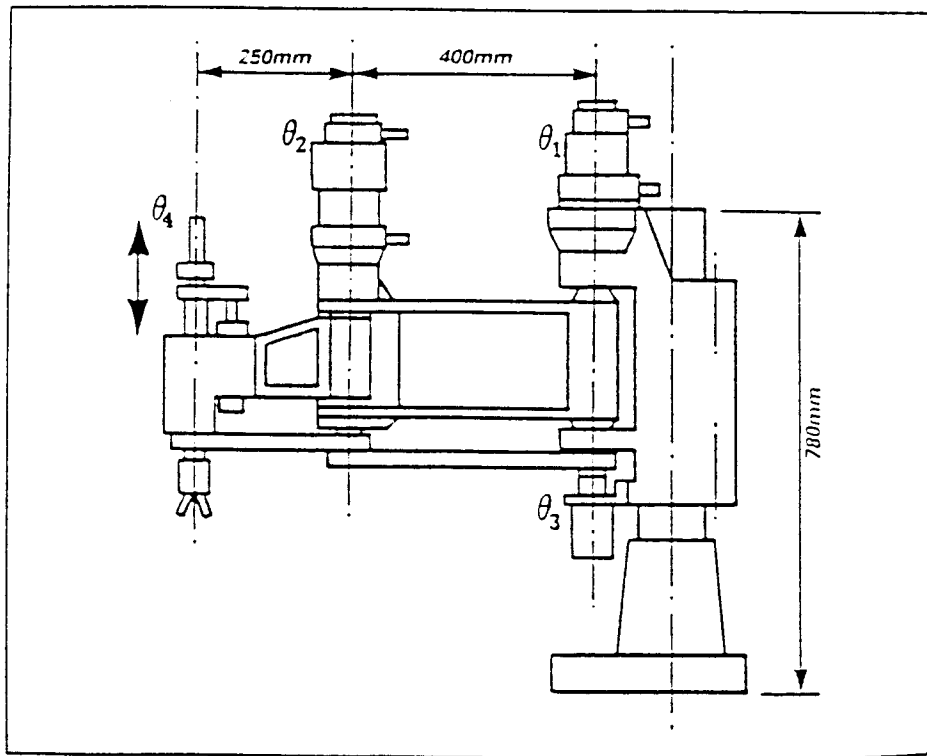

Figure 2.1 SCARA robot arm configuration

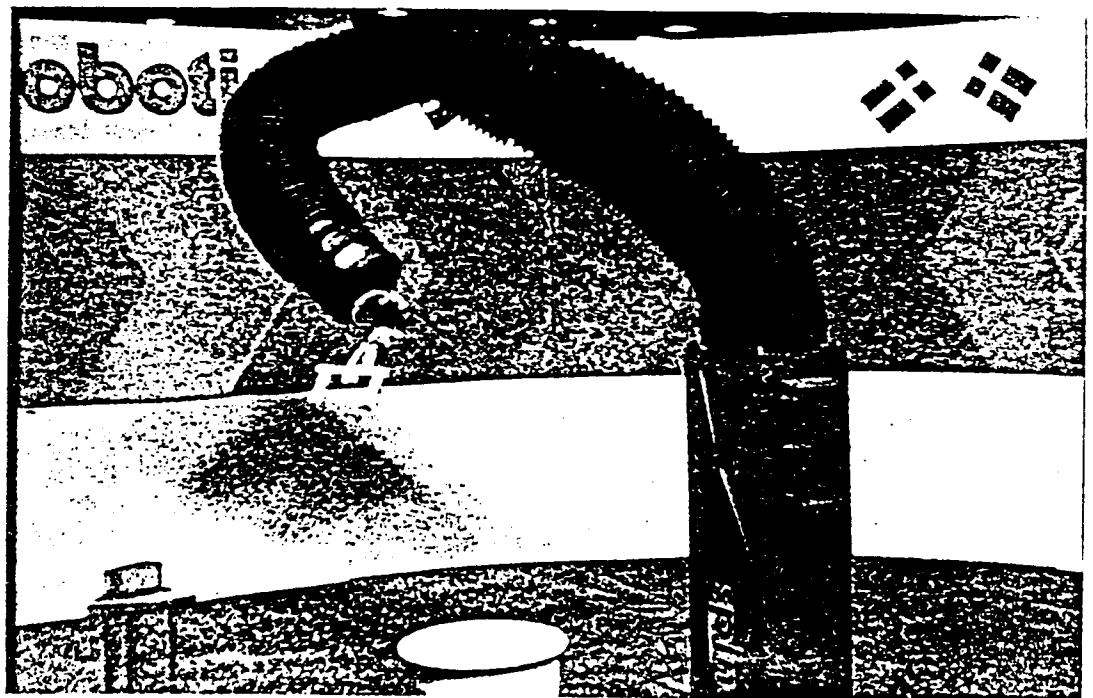

Figure 2.2 SPINE robot arm