

## MECH307 EXAM I (Example Questions)

NAME: \_\_\_\_\_

NOTE:

- CLOSED BOOK, CLOSED NOTES.
- NO CALCULATORS ALLOWED.
- DO YOUR WORK ON THE EXAM ONLY (NO SCRATCH PAPER ALLOWED).
- READ THE QUESTION AND ALL ANSWERS CAREFULLY AND SELECT THE **BEST** ANSWER.
- ALL QUESTIONS ARE WEIGHTED EQUALLY.

USEFUL EQUATIONS:

Resistor Color Codes:

Black:0, Brown:1, Red:2, Orange:3, Yellow:4, Green:5, Blue:6, Violet:7, Grey:8, White:9  
Gold:  $\pm 5\%$ , Silver:  $\pm 10\%$

Complex Impedances:

$$Z_R = R \quad Z_C = \frac{1}{j\omega C} = -\frac{j}{\omega C}, \quad Z_L = j\omega L$$

- (1) Select the statement below that is most true:
- a mechatronic system is usually a small component (sub system) within a measurement system.
  - a measurement system is usually a small component (sub system) within a mechatronic system.
- (2) A pF is equivalent to
- $10^{-3}$  F
  - $10^{-6}$  F
  - $10^{-9}$  F
  - $10^{-12}$  F
  - $10^{-15}$  F

- (3) In a dc electrical circuit, electrons flow from
- the negative side of the voltage source to the positive side.
  - the positive side of the voltage source to the negative side.
- (4) A 1 kV voltage across a 10 M $\Omega$  resistor will produce a current of
- 10 kA
  - 0.1 kA
  - 10 mA
  - 1 mA
  - 0.1 mA
- (5) What is the nominal (average) resistance value of a resistor with color bands: a=gray, b=orange, c=black?
- 83
  - 38
  - $3 \times 10^8$
  - 8000
  - 1
- (6) The equivalent resistance of three resistors (each of resistance R) in series is
- R
  - 3R
  - $R/3$
  - $2R/3$
  - $3R/2$

Questions 7 through 10 deal with the circuit below where:

$R_1=1\text{k}\Omega$ ,  $R_2=9\text{k}\Omega$ ,  $R_3=10\text{k}\Omega$ ,  $R_4=1\text{k}\Omega$ ,  $R_5=1\text{k}\Omega$ ,  $V_1=5\text{V}$ , and  $V_2=10\text{V}$ .

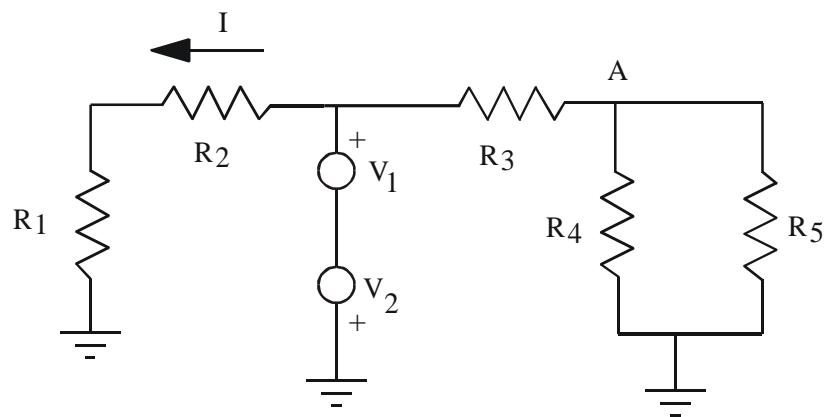

- (7) What is the equivalent resistance between node A and ground?
- 1000  $\Omega$
  - 2 k $\Omega$
  - 0  $\Omega$
  - 0.5  $\Omega$
  - 500  $\Omega$
- (8) What is the voltage across  $R_1$ ?
- 5 V
  - 0 V
  - 9 V
  - 4.5 V
  - 0.5 V
- (9) What is the current (I) through resistor  $R_2$  given the direction shown?
- 0.5 mA
  - 0.5 A
  - 0.5 mA
  - 1.0 mA
  - 1.0 A
- (10) What is the voltage at node A?
- 0.238 kV
  - 0.238 mV
  - 0.238 V
  - 0.238 V
  - 0.238 mV

Questions 11 through 13 deal with the circuit below where:

$V_s=10\text{V}$  dc,  $R_1=1\text{k}\Omega$ ,  $R_2=1\text{k}\Omega$ , and  $C=0.01\mu\text{f}$

Assume the circuit is operating in steady state (transients are already dissipated).

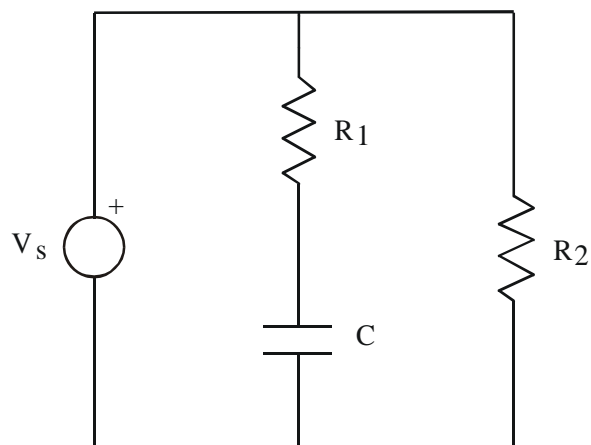

- (11) What is the voltage across  $R_1$ ?
- (a) 20 V
  - (b) 10 V
  - (c) 5 V
  - (d) 0 V
  - (e) -20 V
- (12) What is the voltage across  $R_2$ ?
- (a) 20 V
  - (b) 10 V
  - (c) 5 V
  - (d) 0 V
  - (e) -20 V
- (13) What is the voltage across C?
- (a) 20 V
  - (b) 10 V
  - (c) 5 V
  - (d) 0 V
  - (e) -20 V
- (14) When an ammeter is used to measure the current in a circuit branch, the meter will introduce a voltage drop in the branch which
- (a) increases with increasing current
  - (b) decreases with increasing current
  - (c) is independent of current
- (15) When measuring the voltage across a circuit branch with a voltmeter, the reading will have the largest percentage error when the branch has
- (a) small resistance
  - (b) large resistance
  - (c) no resistance

Questions 16 through 18 deal with the circuit below where:

$$V_s = 2 \sin(100t) \text{ V}, R_1 = 1 \text{ k}\Omega, R_2 = 1 \text{ k}\Omega, \text{ and } C = 1 \mu\text{f}$$

Assume the circuit is operating in steady state (transients already gone),

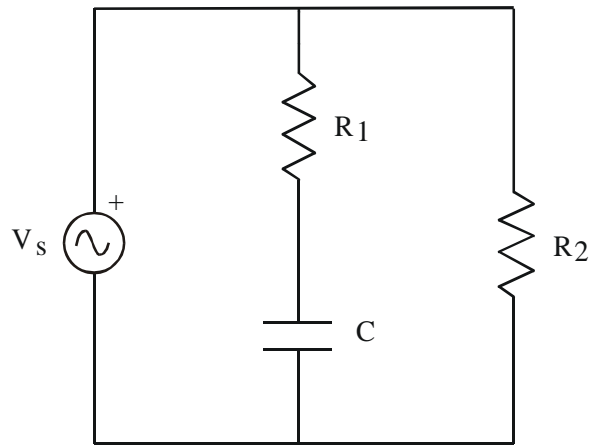

- (16) What is the voltage across  $R_2$ ?
- (a)  $2 \sin(100 t)$
  - (b)  $1 \sin(100 t)$
  - (c) 2
  - (d) 1
  - (e) 0
- (17) What is the polar form of the equivalent impedance (in  $\Omega$ ) across the  $R_1$ - $C$  branch?
- (a)  $10050 \angle 84.3^\circ$
  - (b)  $10050 \angle -84.3^\circ$
  - (c)  $1005 \angle -5.71^\circ$
  - (d)  $1005 \angle 5.71^\circ$
  - (e)  $1000 \angle 0$
- (18) For very high input frequencies [ $V_s = 2 \sin(\omega t)$  where  $\omega$  is large], the voltage across  $C$  approaches
- (a)  $2 \sin(100 t)$
  - (b)  $1 \sin(100 t)$
  - (c) 2
  - (d) 1
  - (e) 0

Questions 19 through 21 deal with the circuit below:

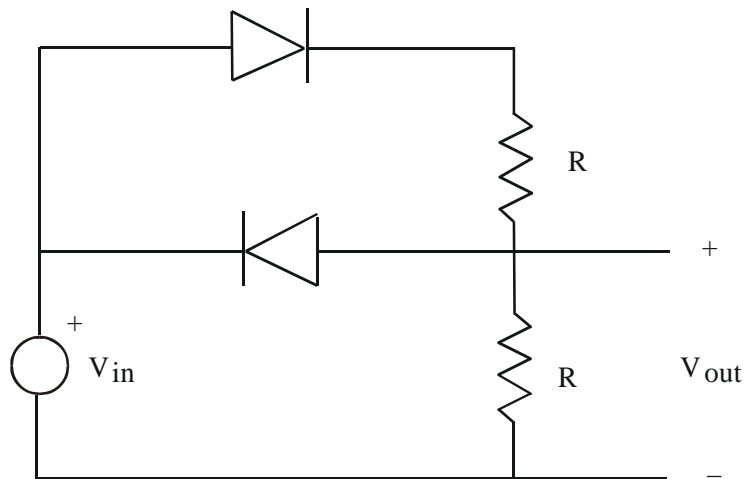

- (19) When  $V_{in}$  is positive and the diodes are assumed to be ideal (no drop),  $V_{out}$  is equal to
- $-V_{in}$
  - 0
  - $V_{in}$
  - $V_{in}/2$
  - $-V_{in}/2$
- (20) If  $V_{in}$  is 5 V and the diodes are assumed to be ideal (no drop), the voltage across the top diode is
- 0
  - 2.5 V
  - 5 V
  - 10 V
  - infinite
- (21) If  $V_{in}$  is a sine wave and the diodes are assumed to be ideal (no drop), which of the following describes the output  $V_{out}$ ?
- half-rectified sine wave (bottom half chopped off at 0V)
  - full-rectified sine wave (bottom half inverted)
  - a full sine wave with the top halves having the same amplitude as the bottom halves
  - a full sine wave with the top halves having different amplitude from the bottom halves
- (22) If the voltage at the emitter of an npn bipolar transistor is 5 V and the transistor is in saturation, the voltage at the collector is approximately
- 5.0 V
  - 5.2 V
  - 5.7 V
  - 4.8 V
  - 4.3 V

- (23) The hexadecimal equivalent of the binary number 1101 is  
 (a) A  
 (b) B  
 (c) C  
 (d) D  
 (e) E
- (24) The binary sum of the binary numbers 1001 and 0011 is  
 (a) 1101  
 (b) 1011  
 (c) 1001  
 (d) 1110  
 (e) 1100
- (25)  $A + A$  is equivalent to  
 (a) A  
 (b) 0  
 (c) 1
- (26)  $A\bar{A}$  is equivalent to  
 (a) A  
 (b) 0  
 (c) 1
- (27) An all-OR realization of  $B(C + \bar{A})$  is  
 (a)  $B + C + A$   
 (b)  $B + \overline{\bar{C} + A}$   
 (c)  $\overline{B + \bar{C} + A}$   
 (d)  $\overline{\bar{B} + C + \bar{A}}$   
 (e)  $\overline{\overline{\bar{B} + C + \bar{A}}}$

Questions 28 through 30 deal with the circuit below

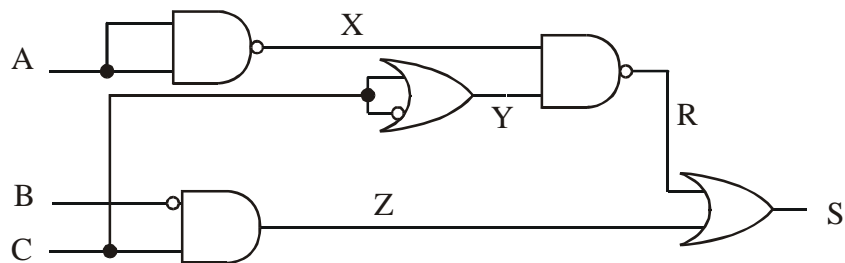

(28) What is a simplified Boolean expression for X?

- (a) A
- (b)  $\bar{A}$
- (c) 0
- (d) 1

(29) If A=1, B=1, and C=1, what is X?

- (a) 0
- (b) 1

(30) If X=0, Y=1, and Z=1, what is S?

- (a) 0
- (b) 1

Question 31 deals with the truth table below where A and B are inputs and X and Y are outputs

A	B	X	Y
1	0	1	0
0	1	1	1
1	1	0	1

(31) Using the sum-of-products method, what is the correct expression for X?

- (a)  $A + B$
- (b)  $A + \bar{B}$
- (c)  $AB$
- (d)  $A\bar{B} + \bar{A}B$
- (e)  $\bar{A}B + A\bar{B}$

(32) A simplified Boolean expression for  $(A\bar{B}) + (A(A + B))$  is

- (a) A
- (b) B
- (c)  $A + B$
- (d) 1
- (e) 0

(33) If the D input of a positive edge-triggered D flip-flop is connected to ground, at every positive edge of the clock input (CK) the output

- (a) changes to (or remains at) 0
- (b) changes to (or remains at) 1
- (c) remains unchanged
- (d) toggles

- (34) If a flip-flop has a "Preset" input marked with an inversion circle, applying a HI signal to this input will
- (a) make the output of the flip-flop go HI
  - (b) make the output of the flip-flop go LO
  - (c) always make the output toggle
  - (d) have no effect on the output of the flip-flop

Questions 35 through 36 deal with the circuit below:

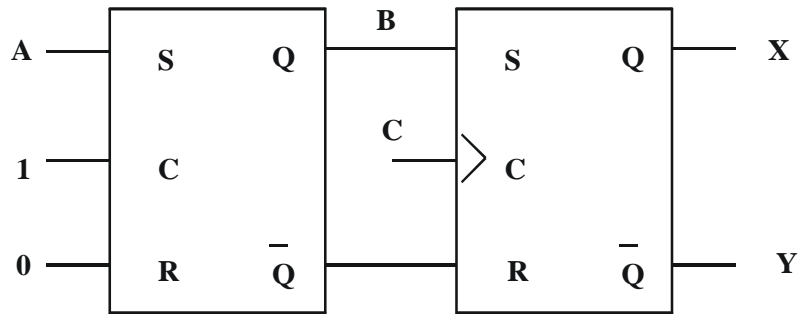

- (35) If A changes from 1 to 0, B will be
- (a) definitely 0
  - (b) definitely 1
  - (c) uncertain (depends on the power-on state and signal histories)
- (36) If B=1 while C changes state from 1 to 0, X will
- (a) become (or remain) 0
  - (b) become (or remain) 1
  - (c) remain unchanged (regardless of whether the initial value is 0 or 1)