

NOTICE:
THIS MATERIAL MAY BE
PROTECTED BY
COPYRIGHT LAW
(17 U.S.C. CODE)

Multipulley Belt Drive Mechanics: Creep Theory vs Shear Theory

D. G. Alciatore
Department of Mechanical Engineering,
Colorado State University,
Fort Collins, CO 80523

A. E. Traver
Department of Mechanical Engineering,
University of Texas,
Austin, TX 78746

This paper investigates two belt mechanics theories and discusses the situations and materials for which they apply. Traditional creep theory is presented along with shear theory which was recently introduced to describe the behavior of steel-reinforced belts. Emphasis is placed on determination of tensions in the spans of a running belt and on applying results to multipulley configurations.

1 Introduction

Belt mechanics theory is not a new concept. The well-established creep theory was originally put forth by Reynolds in 1847 [1] and further developed by Swift in 1928 [2]. Creep theory defines the action taking place in a running elastic belt. The underlying principles of the theory along with an extension to multipulley systems considering the effects of span length proportions is presented in Section 2.

When creep theory was put forth, the types of belts in use were leather or woven cloth flat belts. Their application was typically in the transmission of large amounts of power in industrial applications. Early drives usually consisted simply of two pulleys transmitting power between two parallel shafts. More recently belts have been applied to more complicated configurations. Multiple belt drives, twisted belt drives, and multipulley drives are just a few such examples. With changing applications, the form and materials used for belts has also changed a great deal. V-belts are the most common including urethane rubber and steel reinforced plain, ribbed, and toothed varieties.

Much empirical data is available for the many standardized V-belt varieties. This data provides information on fatigue and bending properties which allow a designer to select a belt for his application. Designers apply the well-established creep theory to derive load belt tensions from their power requirements. This paper points out that the application of creep theory to some configurations and to some belt types is incorrect. Firbank first proposed in 1970 [3] that creep theory did not provide an accurate representation of belt mechanics for belts which contain steel reinforcement strands. His results are based on the fact that reinforced belts are for all practical purposes inextensible (due to the stiffness of steel within them). His ideas are presented in Section 3 and results are applied to multipulley configurations.

Despite the vast amount of empirical data available concerning V-belt power transmission design, very little has been done to develop belt mechanics theory which would apply to the various belt types currently in use. It should be noted that even though it is important to develop theory, empirical data

is a necessity. The many assumptions necessary to develop a concise belt mechanics theory may lead to models which are accurate only for very specific and limited conditions. Examples of error sources are coefficient of friction changing with temperature, slip speed, and moisture, and material behavior being nonlinear or possessing hysteresis. Despite the unsure nature of some assumptions, the development of a descriptive theory is necessary to provide a designer with a tool to make decisions based on factors which empirical data or current theories do not address.

2 Application of Creep Theory

Creep theory describes the transmission of power between a running pulley and an elastic belt. The name "creep" comes from the fact that frictional forces cause a change in belt tension thereby causing the elastic belt to extend and contract. This action results in relative motion between the belt and pulley surfaces which is termed elastic creep. The theory does make some simplifying assumptions concerning friction and elasticity which do not apply exactly to all materials and running conditions; nevertheless, creep theory has been accepted and used for design purposes for over a century.

Most mechanics and design textbooks present creep theory and how it applies to simple two-pulley drives. These simple equations are often erroneously applied to more complex drive configurations and to materials for which the friction and elasticity assumptions are invalid. The application of creep theory to the classic simple two-pulley drive, and an extension to multipulley configurations is presented in the next few sections.

2.1 Two-Pulley Theory. The description of belt-pulley mechanics begins with an analysis of friction at the belt-pulley interface. This analysis yields the familiar result:

$$\frac{T_1}{T_2} = e^{(\mu\phi)} \quad (1)$$

which relates belt span tensions on either side of a pulley to the coefficient of friction, μ , and the active angle, ϕ , (where T_1 is the greater of the two tensions). (Refer to Fig. 1 for illustration of terms.) This active angle over which the belt tension changes exists only over a portion of the total angle

Contributed by the Power Transmission and Gearing Committee for publication in the JOURNAL OF MECHANICAL DESIGN. Manuscript received November 1989. Technical Editor: Kenneth J. Waldron.

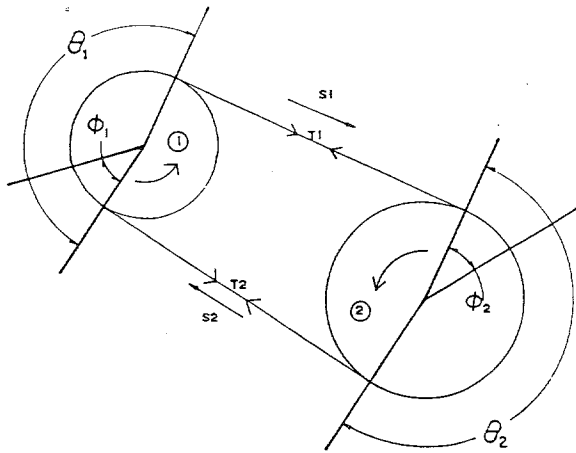

Fig. 1 Two-pulley system

of wrap, θ . Experiments have shown that the active angle occurs at the leaving end of the pulley (as shown in Fig. 1). The tension in the belt changes exponentially from one span to the next over the active angle.

The changing of belt tension creates changes in strain in the elastic belt which requires that the belt move relative to the rotating pulley. A speed differential develops between the belt and pulley which is commonly termed creep. The belt span at the higher tension is traveling at a slightly faster speed than the lower tension span ($S_1 > S_2$). Denoting an assumed constant belt speed by S (in fpm = .3048 m/s) and the power transmitted by hp (in units of horsepower = 745.7 W), the span tensions (in lbs = 4.448 N) can be related by:

$$T_1 - T_2 = \frac{33000 \text{ hp}}{S} \quad (2)$$

The span tensions may also be related by considering the elastic deformation taking place in the length of the belt. These changes in belt length can be expressed as:

$$dl = \frac{dT}{k} \quad (3)$$

for linear elastic behavior (k : constant) where dT is the change in the belt span tension from the initial preset tension, T_s , to the tension at running conditions. Requiring that the total belt length remain constant (by equating the magnitudes of the belt length changes) and assuming that half of the belt is at tension T_1 and the other is at T_2 yields the following expressions for the span tensions:

$$T_1 = T_s + \frac{16500 \text{ hp}}{S} \quad T_2 = T_s - \frac{16500 \text{ hp}}{S} \quad (4)$$

These tensions will exist in the running belt only if the initial preset tension is large enough to have the ratio T_1/T_2 remain below the limit predicted by the friction relation, (equation (1)).

2.2 Bending and Centrifugal Effects. Bending of the belt when rounding a pulley has negligible effect on belt tension when the belt is flexible (as with flat, thin belts). Some belt types, however, are fairly stiff and other significant resistance to bending. Bending effects are usually considered for standard V-belts especially when used with small diameter sheaves. The increase in tension due to bending has been shown to be related to sheave diameter as:

$$dT_b = \frac{K_b}{d} \quad (5)$$

where K_b is an experimentally determined constant which is

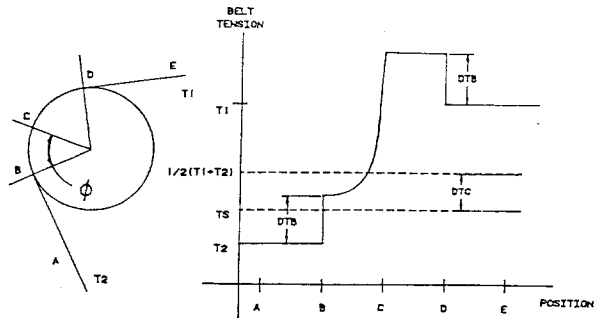

Fig. 2 Bending and centrifugal effects

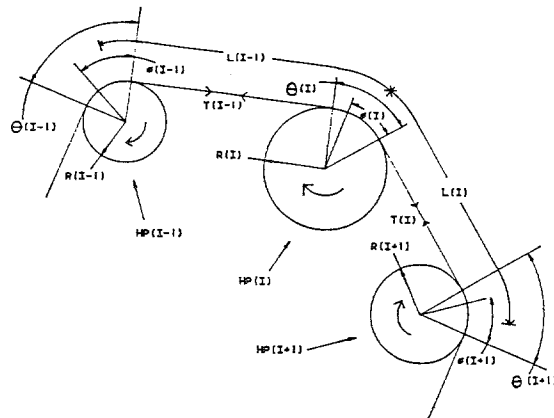

Fig. 3 Multipulley terminology

reported by SAE for most standard belt sections [4]. K_b ranges from 200 to 11000 for SAE V-belt sections A through E (where the sheave diameter, d , is in inches = 2.54 cm and the resulting tension increase is in lbs = 4.448 N).

Centrifugal effects must be considered when the belt has significant mass and/or when the belt speeds are high. Centrifugal forces on the running belt cause an increase in the belt tension and also a decrease in pressure at the belt-pulley interface which can lead to slip. Centrifugal effects have been considered for standard V-belts and the predicted increase in tension has been found to be related to belt speed as:

$$dT_c = K_c \left(\frac{S}{1000} \right)^2 \quad (6)$$

where K_c is an experimentally determined constant which is reported for SAE standard belt sections [4]. K_c ranges from 0.5 to 5.1 for SAE V-belt section A through E (where S is the belt speed in fpm = .3048 m/s and the resulting tension increase is in lbs = 4.448 N).

Figure 2 illustrates the effects both bending and centrifugal considerations have on tension in a running belt. The centrifugal effect (dT_c) is felt by both spans (as with the preset tension T_s). The bending effects apply only to the portion of the belt rounding the pulley (sheave).

2.3 Extension to Multipulley Configurations. As was mentioned earlier, the span tension equations derived for the two-pulley case [equation (4)] cannot be applied correctly to more complex configurations. The action of creep must be considered throughout the belt system before local span tensions can be derived.

Figure 3 defines the terminology as applied to a general multipulley configuration. As with the two-pulley derivation, linear elastic belt behavior is assumed. Changes in belt length due to span tension changes are found from $dl = (T - T_s)/k$

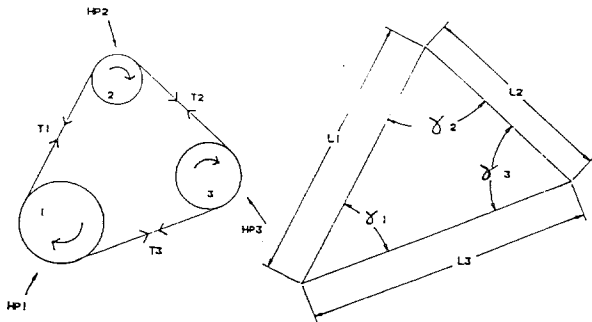

Fig. 4 Three-pulley system with span length approximation

[equation (3)] where the stiffness k depends on the length of the span in question ($k = AE/l$). The requirement that the total belt length remain constant (satisfied by equating the algebraic sum of the span tension length changes to zero) yields the following equation:

$$\sum_{i=1}^n l_i T_i = L T_s \quad (7)$$

where L is the total belt length. The span lengths l_i can be approximated to extend between active angle (or even wrap angle) bisectors as shown in Fig. 3. This equation will be referred to as the compatibility condition. Equations relating the span tensions to the power transferred at each pulley are also available:

$$T_{i-1} - T_i = \frac{33000 hp_i}{S} \quad (8)$$

where the power transferred (hp_i) is positive for a driving pulley and negative for a driven pulley. For an n -pulley configuration, $n-1$ independent pulley power equations and the length change compatibility condition equation can be solved simultaneously to find the desired span tensions. Bending and centrifugal effects discussed in the previous section can also be applied here resulting in a modified compatibility condition:

$$\sum_{i=1}^n l_i T_i = L (T_s + T_c) - \sum_{i=1}^n T_{bi} r_i \theta_i \quad (9)$$

Using the expressions for T_c and T_b prescribed by SAE results in:

$$\sum_{i=1}^n l_i T_i = L \left(T_s + K_c \left(\frac{S}{1000} \right)^2 \right) - \frac{K_b}{2} \sum_{i=1}^n \theta_i \quad (10)$$

The sum on the right hand side can be found easily from belt geometry. For an n -pulley system with noncrossing belt spans the sum of the wrap angles (which are the supplements of the angles included by adjacent span lengths) is simply 2π .

2.4 Three-Pulley Configuration—A Closer Look. The three-pulley configuration is the simplest and most common of the multipulley systems and deserves a closer look.

Figure 4 illustrates a typical three-pulley system along with a method for approximating the span lengths with a triangle formed by the angles between the spans. This approximation becomes a better one when the span lengths are relatively large. The compatibility condition [equation (7)] in its original form and with the span length simplification (using the law of sines) follow:

$$l_1 T_1 + l_2 T_2 + l_3 T_3 = L T_s$$

$$\sin(\gamma_3) T_1 + \sin(\gamma_1) T_2 + \sin(\gamma_2) T_3 = SN T_s \quad (11)$$

where:

$$SN = \sin(\gamma_1) + \sin(\gamma_2) + \sin(\gamma_3)$$

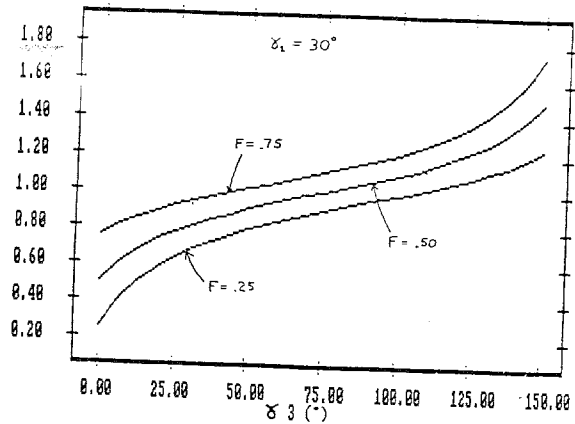

Fig. 5 Maximum tension factor (Z vs 3rd pulley span angle (γ_3))

Substituting power expressions [equation (8)] for the first two span tensions yields the third tension:

$$T_3 = T_s - \frac{33000}{SN S} (\sin(\gamma_1) hp_2 - \sin(\gamma_3) hp_1) \quad (12)$$

The other two tensions, T_1 and T_2 can be found by substituting T_3 into the power expressions. For the common case where power is being entered at one pulley ($hp_1 > 0$) and dissipated at the other two ($hp_2, hp_3 < 0$), the tension in the third span is the maximum tension experienced in the belt. Introduction of another term, F , the third pulley power factor, which expresses the fraction of the input power dissipated by the third pulley ($F = -hp_3/hp_1$), further simplifies the maximum tension equation:

$$T_3 = T_s + \frac{16500 hp_1}{S} \left[\frac{2(F \sin(\gamma_1) + \sin(\gamma_3))}{SN} \right] \quad (13)$$

This value deviates from that predicted by the two-pulley results [equation (4)] applied at pulley 1 by the quantity in brackets which will be called the maximum tension factor Z . Figure 5 demonstrates how this factor changes with the third pulley power factor and span angle (for $\gamma_1 = 30$ deg). The curves predict that Z and, therefore, the maximum tension are smaller when the third pulley is more remote (for γ_3 closer to zero). The factor Z can also be used as a gage of the two-pulley theory error (when applied to the three-pulley case)—the error is larger the farther away Z is from one.

2.5 Solution by Computer Program. A program was written to implement the creep theory multipulley procedure for determining span tensions [5]. Table 1 and Fig. 6 contain the results for a sample case. The required coefficient of friction reported refers to the value necessary to prevent slip (to prevent the active arcs from exceeding the wrap angles) for the given span tensions. RB refers to the bearing reaction force at each pulley. The two-pulley comparison reports the error involved in using the two-pulley span tension equations [equation (4)] at each pulley. The largest two-pulley theory span tension for this example error was 43 percent. Note that the maximum tension (T_3) was underestimated by the two-pulley equations (see the previous section for the discussion of the maximum tension factor Z).

3 Application of Shear Theory

Creep theory was developed to describe belt-drive mechanics of flexible and extensible load carrying belts. The types of belts in use when the theory was developed were of the leather and woven cloth variety for which the assumptions of flexibility and extensibility do apply. These assumptions, however, do

Table 1

ith Pulley	Cx (in)	Cy (in)	r (in)	l _i (in)
1	0.000	0.000	1.000	6.145
2	4.000	2.000	1.500	9.969
3	8.000	0.000	2.000	2.049

ith Pulley	hp	T _i (lb)	RB (lb)
1	3.000	48.59	187.4
2	-1.000	81.59	65.3
3	-2.000	147.6	227.8

Belt linear speed = 1000 fpm
 Initial belt tension = 100 lb
 Required coefficient of friction = .559

Two-Pulley Comparison

ith span	T (lb)	2-pulley T (lb)	% error
1	48.59	50.50	3.92
2	81.59	116.5	42.78
3	147.6	133.0	-9.89

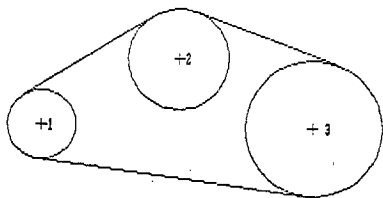

Fig. 6 "Program BELT" graphics output

not apply to the now common V-belts and conveyor belts which consist of stiff load carrying fibers (usually steel) surrounded by an envelope of resilient material (usually rubber). These belts are far superior to their predecessors due to the excellent friction characteristics of the envelope and the high load capacity made possible by the high strength reinforcing fibers.

In 1970 Firbank first proposed that the well-established creep theory and its assumptions do not apply to an inflexible, inextensible belt [3]. He pointed out that the high stiffness of the reinforcing fibers "render the belt virtually inextensible during operation" therefore violating the main assumption underlying creep theory. Firbank concludes that shear strains in the belt envelope between the reinforcing fibers and the pulley surface are a large factor in belt mechanics behavior. Firbank's theory is presented in this chapter along with the application of its results to multipulley configurations. The results are compared to those of creep theory and differences are pointed out.

3.1 Firbank's Theory. Assumptions made by Firbank in his analysis of the inextensible belt include the following: the load carrying reinforcing fibers are inextensible and flexible; the kinetic coefficient of friction, μ_k , is constant and the static value has a fixed limiting value, μ_s ; centrifugal effects may be neglected. He shows that a constant speed differential exists between the running belt load carrying fibers and the pulley surface. This differential causes shear strains, γ , to build up in the belt envelope to a point where the friction forces are overcome resulting in slip. The arc of contact consists of two distinct regions: the arc of slip a occurring at the leaving end of the pulley (which is identical to the active arc in creep theory), and the arc of adhesion $(\theta - \alpha)$ over which static friction forces provide traction. Creep theory predicted no traction in this portion of the arc of contact. Figure 7 illustrates

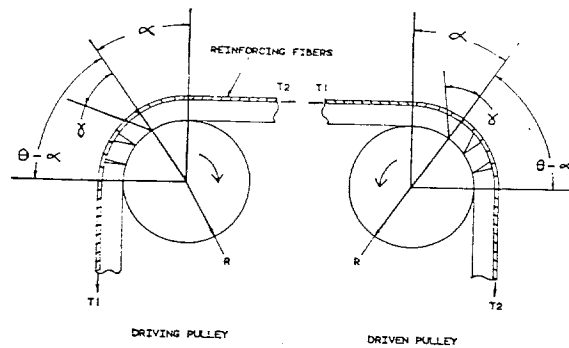

Fig. 7 Shear theory terminology

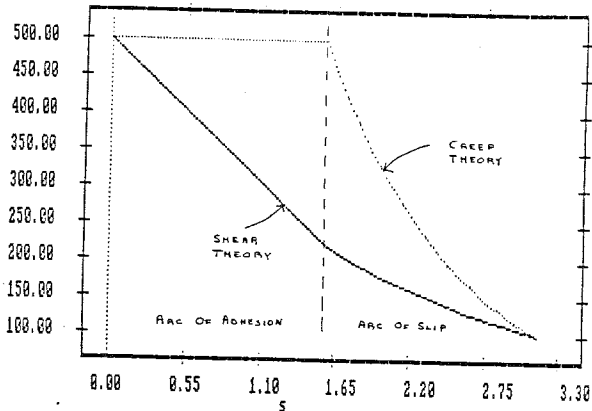

Fig. 8 On pulley tension versus pulley angle

these concepts on both a driving (power supplying) pulley and a driven (power dissipating) pulley. (Note— $T_1 > T_2$). Figure 8 illustrates how shear theory differs from creep theory in describing the action over the arc of contact.

The change in belt tension that occurs over the arc of slip can be expressed as:

$$T_2(e^{\mu_k \alpha} - 1) \quad (14)$$

since $T/T_2 = e^{\mu_k \alpha}$ over this arc. At the interface of the arcs of slip and adhesion, the tractive force per unit length at the pulley surface is equal to the product of the coefficient of static friction and the normal force per unit length:

$$\mu_s \left[\frac{T_2 e^{\mu_k \alpha}}{R} \right] \quad (15)$$

This tractive force builds up linearly as do the shear strains from the entry point; therefore, the change in belt tension over the arc of adhesion (which is equivalent to the sum of the tractive forces) can be expressed as:

$$\frac{(\theta - \alpha)}{2} T_2 e^{\mu_k \alpha} \mu_s \quad (16)$$

Combining the tension changes over the entire arc of contact results in the following expression for the span tension ratio:

$$\frac{T_1}{T_2} = e^{\mu_k \alpha} \left[1 + \frac{(\theta - \alpha)}{2} \mu_s \right] \quad (17)$$

This applies to a driving pulley only; a similar analysis can be carried out for a driven pulley resulting in:

$$\frac{T_1}{T_2} = \frac{e^{\mu_k \alpha}}{\left[1 - \frac{(\theta - \alpha)}{2} \mu_s \right]} \quad (18)$$

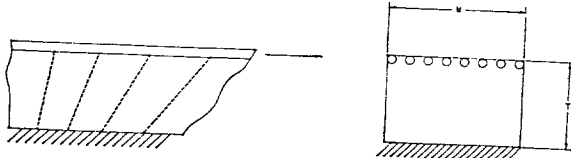

Fig. 9 Firbank's belt model

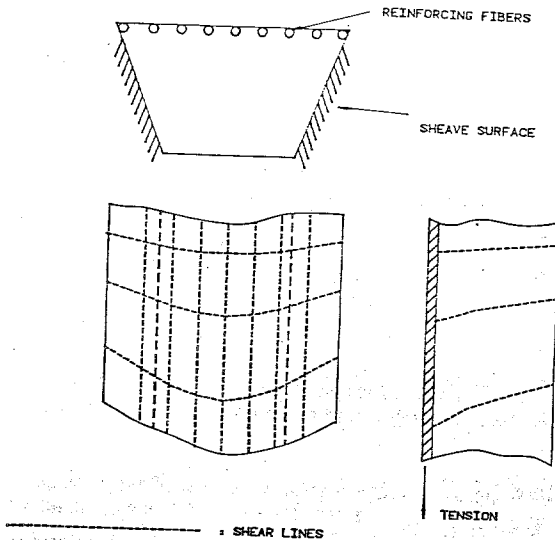

Fig. 10 V-belt model

3.2 Scope of Firbank's Development. Firbank's belt model was that of a flat belt with reinforcing fibers located at the upper surface undergoing a simple shearing action as illustrated in Fig. 9. The results of this simple model cannot be reliably applied to other more complicated belt sections. The shearing action taking place in a V-belt section, for example, is very different as illustrated by Fig. 10. The development of a similar theory specific to V-type belts would require many more parameters including cross section geometry, reinforcement strand spacing and load carrying percentage, and traction distribution on the belt-sheave interface. These factors have been considered by Martynov [6], Gerbert [7], and others but the results are beyond the scope of this discussion.

Despite the apparent inapplicability of Firbank's theory directly to belt sections such as the V-belts, some results can be applied. The shearing action and the inextensibility are also characteristic of the V-belts possessing a flexible envelope reinforced with stiff fibers. These properties alone allow for the prediction of certain behavior. An application of Firbank's theory to multipulley systems and a summary of derived results are presented in the next section.

3.3 Application of Shear Theory to Multipulley Configurations. In creep theory, elastic length changes of the belt spans controlled the derivation of span tensions through the compatibility relation; but in shear theory, length changes are assumed to be negligible—the belt is assumed to be "inextensible." In order to arrive at a compatibility condition for the shear theory multipulley solution, the shear deformations in the belt envelope have to be considered.

Firbank's belt model predicts that as the belt rounds a pulley, the belt's flexible envelope is sheared through an angle γ (see Fig. 7). This angle can be expressed as the ratio of the average shear stress in the arc of adhesion and the modulus of rigidity G of the envelope material. The resulting equations are:

$$\gamma = \frac{1}{WG} \left[\frac{\mu_s T_2}{2r} e^{(\mu_k \alpha)} \right] \quad (19)$$

for a driving pulley [from equation (15)], and:

$$\gamma = \frac{1}{WG} \left[\frac{\mu_s T_1}{2r} e^{(\mu_k \alpha)} \right] \quad (20)$$

for a driven pulley, where W is the belt width.

For the belt to return to its original condition upon completion of a cycle (over all of the pulleys the belt rounds), the algebraic sum of the shear deformations (γ) must equate to zero:

$$\sum_{i=1}^n \gamma_i = 0 \quad (21)$$

This is the compatibility condition for belts satisfying the shear theory (Firbank) assumptions.

In order to determine span tensions, the compatibility condition [equation (21)] along with the power equations [(equation (8))] would have to be solved iteratively due to the appearance of the slip angle α (which depends upon the desired span tensions). Slip angles could be estimated, allowing for span tension solution, and then recalculated from Firbank's span tension ratio equations [equation (17) and equation (18)]. This process could then be repeated in order to converge to the exact solution.

The solution procedure is by no means simple, and the parameters involved in the equations (namely the coefficients of friction) are difficult to determine for most running conditions. These factors would imply that application of the method would be infeasible and unreliable; however, the analysis does predict the following statements which relate to creep theory conclusions: (1) Span tensions in an "inextensible" belt are independent of span lengths in a multipulley system. (2) The span tensions are highly dependent upon both the kinetic and static coefficients of friction.

4 Conclusions

This paper summarized how creep theory and shear theory describe belt drive mechanics. Traditional creep theory, which forms the basis for common belt design equations, was shown to be inapplicable to belts which are steel-reinforced. Belts containing steel fibers are very nearly inextensible and so they do not exhibit the elastic creep behavior that forms the basis for creep theory. Shear theory was recently developed to better describe the mechanics of steel-reinforced belts. The increased commonplace of such belts has warranted this more descriptive theory.

Both creep theory and shear theory results have been applied only to simple two-pulley drives. It was shown that these results cannot be correctly applied to multipulley configurations. This paper extended the hypotheses of both theories to belt drives with any number of pulleys. The end result was the determination of span tension throughout the belt. These tensions are important for design purposes in choosing a belt cross section and in predicting belt life. The creep theory solution was firmly straightforward and a computer program which solves for span tensions in an arbitrary planar multipulley system was developed. The shear theory development proved to be more involved, but nonetheless, some basic and important conclusions were easily drawn.

Creep theory applies to homogeneous belts which can be characterized as extensible. Leather, woven cloth, and urethane belts are examples of this type of belt. Creep theory predicts that the span tensions are dependent upon span length proportions alone, and are independent of variations in frictional

properties provided that the kinetic coefficient of friction remains large enough to prevent gross slip. Shear theory applies to steel-reinforced belts, such as SAE standard V-belts and flat conveyor belts, which are practically inextensible. Shear theory predicts that the span tensions are independent of span length proportions, but are highly dependent upon both the kinetic and static coefficients of friction.

Acknowledgments

The authors express their gratitude to Arthur H. Burr for his help in reviewing and commenting on early drafts of this paper.

References

- 1 Reynolds, O., "Creep Theory of Belt Drive Mechanics," *The Engineer*, Vol. 38, No. 396, 1847.
- 2 Swift, H. W., "Power Transmission by Belts: An Investigation of Fundamentals," *Proceedings of the Institute of Mechanical Engineers*, Vol. 2, No. 659, 1928.
- 3 Firkbank, T. C., "Mechanics of the Belt Drive," *International Journal of Mechanical Science*, Vol. 12, No. 12, 1970.
- 4 Spotts, M. F., *Design of Machine Elements*, 5th ed., Prentice-Hall, Inc., Englewood Cliffs, NJ, 1978.
- 5 Alciatore, D. A., "Multipulley Belt Drive Mechanics: Creep Theory vs Shear Theory," Masters Thesis, The University of Texas at Austin, Summer, 1987.
- 6 Martynov, V. K., "Tangential Deformations in V-belt Transmissions," *Russian Engineering Journal* 50, No. 3, pp. 44-49, 1970.
- 7 Gerbert, B. G., "Pressure Distribution and Belt Deformation in V-belt Drives," *ASME Journal of Engineering for Industry*, Series B 97, No. 3, pp. 976-982, 1975.



Statement of Ownership, Management, and Circulation (Required by 39 U.S.C. 3685)

1. Publication Title Transaction of the ASME, Journal of Mechanical Design		2. Publication No. 7 0 2 - 3 5 0		3. Filing Date 8/31/95	
4. Issue Frequency Quarterly		5. No. of Issues Published Annually Four		6. Annual Subscription Price \$175.00	
7. Complete Mailing Address of Known Office of Publication (Street, City, County, State, and ZIP+4) (Not Printer) 345 East 47th Street, New York, NY 10017					
8. Complete Mailing Address of Headquarters or General Business Office of Publisher (Not Printer) 345 East 47th Street, New York, NY 10017					
9. Full Names and Complete Mailing Addresses of Publisher, Editor, and Managing Editor (Do Not Leave Blank) Publisher (Name and Complete Mailing Address) The American Society of Mechanical Engineers 345 East 47th Street, New York, NY 10017 Editor (Name and Complete Mailing Address) Professor Bahram Ravani, Department of Mechanical, Aerospace & Materials Engineering, University of California, Davis, CA 95616 Managing Editor (Name and Complete Mailing Address) Cornelia Moghan, ASME, 345 East 47th Street, New York, NY 10017					
10. Owner (If owned by a corporation, its name and address must be stated and also immediately thereunder the names and addresses of stockholders owning or holding 1 percent or more of the total amount of stock. If not owned by a corporation, the names and addresses of the individual owners must be given. If owned by a partnership or other unincorporated firm, its name and address as well as that of each individual must be given. If the publication is published by a nonprofit organization, its name and address must be stated.) (Do Not Leave Blank.)					
Full Name		Complete Mailing Address			
The American Society of Mechanical Engineers		345 East 47th Street, New York, NY 10017			
11. Known Bondholders, Mortgagees, and Other Security Holders Owning or Holding 1 Percent or More of Total Amount of Bonds, Mortgages, or Other Securities. If none, check here. <input checked="" type="checkbox"/> None					
Full Name		Complete Mailing Address			
12. For completion by nonprofit organizations authorized to mail at special rates. The purpose, function, and nonprofit status of this organization and the exempt status for federal income tax purposes. (Check one) <input checked="" type="checkbox"/> Has Not Changed During Preceding 12 Months <input type="checkbox"/> Has Changed During Preceding 12 Months (If changed, publisher must submit explanation of change with this statement)					

13. Publication Name Transaction of the ASME, Journal of Mechanical Design		14. Issue Date for Circulation Data Below June	
15. Extent and Nature of Circulation			
		Average No. Copies Each Issue During Preceding 12 Months	Actual No. Copies of Single Issue Published Nearest to Filing Date
a. Total No. Copies (Net Press Run)		2,250	2,250
b. Paid and/or Requested Circulation (1) Sales Through Dealers and Carriers, Street Vendors, and Counter Sales (Not Mailed)		--	--
(2) Paid or Requested Mail Subscriptions (Include Advertisers' Proof Copies/Exchange Copies)		1,814	1,711
c. Total Paid and/or Requested Circulation (Sum of 15b(1) and 15b(2))		1,814	1,711
d. Free Distribution by Mail (Samples, Complimentary, and Other Free)		89	113
e. Free Distribution Outside the Mail (Carriers or Other Means)		--	--
f. Total Free Distribution (Sum of 15d and 15e)		89	113
g. Total Distribution (Sum of 15c and 15f)		1,903	1,824
h. Copies Not Distributed (1) Office Use, Leftovers, Spoiled		347	426
(2) Return from News Agents		--	--
i. Total (Sum of 15g, 15h(1), and 15h(2))		2,250	2,250
Percent Paid and/or Requested Circulation (15c / 15i x 100)		95%	94%
16. This Statement of Ownership will be printed in the <u>December</u> issue of this publication. <input type="checkbox"/> Check box if not required to publish.			
17. Signature and Title of Editor, Publisher, Business Manager, or Owner <i>Claire Spitz, Research Analyst</i>		Date 8/17/95	
I certify that all information furnished on this form is true and complete. I understand that anyone who furnishes false or misleading information on this form or who omits material or information requested on the form may be subject to criminal sanctions (including fines and imprisonment) and/or civil sanctions (including multiple damages and civil penalties).			

Instructions to Publishers

1. Complete and file one copy of this form with your postmaster on or before October 1, annually. Keep a copy of the completed form for your records.
 2. Include in items 10 and 11, in cases where the stockholder or security holder is a trustee, the name of the person or corporation for whom the trustee is acting. Also include the names and addresses of individuals who are stockholders who own or hold 1 percent or more of the total amount of bonds, mortgages, or other securities of the publishing corporation. In item 11, if none, check box. Use blank sheets if more space is required.
 3. Be sure to furnish all information called for in item 15, regarding circulation. Free circulation must be shown in items 15d, e, and f. Circulation must be published; it must be printed in any issue in October or the first printed issue after October, if the publication is not published during October.
 4. In item 16, indicate date of the issue in which this Statement of Ownership will be printed.
 5. Item 17 must be signed.
- Failure to file or publish a statement of ownership may lead to suspension of second-class authorization.