

ECE Connections: What do Roots of Unity have to do with OP-AMPs?

Louis Scharf, Colorado State University

PART 1: Why Complex?

1. Curiosity, My favorite curiosity is j^j :

$$j^j = (e^{j\frac{\pi}{2}})^j = e^{-\frac{\pi}{2}} = 0.207\dots$$

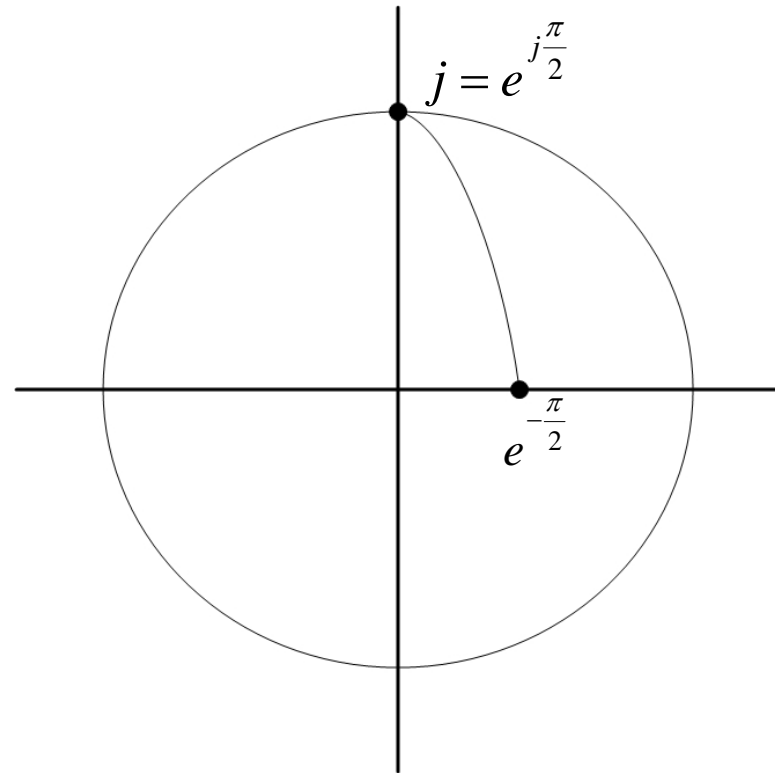

2. **Question**, But what about the questions before us,

“If everything we build and measure is *real*, why do we use *complex* analysis? And, what do the *complex* roots of unity have to do with *real* OP-AMPs?”

3. **Answer**. Yes, everything we build and measure *is* real. But everything we build has *two real channels* (either actual or virtual) and these two channels are conveniently represented with *one complex channel*. This is the bottomline answer.

For many of the examples to follow, complex analysis *simplifies our life*. For one of the examples, there *would be no life* without complex analysis.

4. **The General Idea**, Replace two real channels with one complex channel.

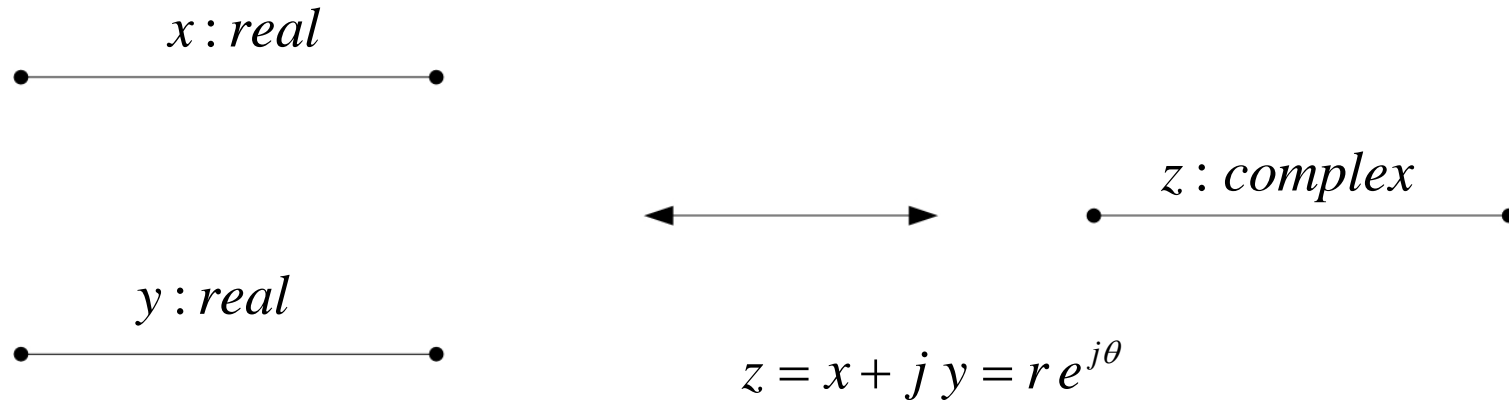

The real part of z codes for (or stands for) the x -channel, and the imaginary part of z codes for the y -channel.

What does the double arrow \longleftrightarrow mean?

$$(x, y) \rightarrow z : z = x + j y = r e^{j\theta} : r^2 = x^2 + y^2, \theta = \arctan y / x$$

$$(x, y) \leftarrow z : x = \operatorname{Re} z = \frac{z + z^*}{2}, y = \frac{z - z^*}{2}; x = r \cos \theta, y = r \sin \theta$$

$z = x + j y$ is the unreal operator. Or, is it the unimaginaire operator?

4. The General Idea (continued): $z = x + j y$

- x : real — Real temporal mode (or eigenvector) $\cos \omega t$
 - y : real — Real temporal mode (or eigenvector) $\sin \omega t$
 - z : complex — Complex temporal mode (or eigenvector) $\cos \omega t + j \sin \omega t = e^{j\omega t}$
-
- x : real — Real spatial mode (or x -coordinate) of a field
 - y : real — Real spatial mode (or y -coordinate) of a field
 - z : complex — Complex representation of a 2 dimensional field
-
- x : real — Real causal part of a signal
 - y : real — Real anti-causal part of a signal
 - z : complex — Complex representation of a two-sided signal

5. **Example 1:** Phasors (ECE 202, 311, 331, 341, 444, 457). Phasors represent real signals.

$$x(t) = A \cos(\omega t + \theta) = A \cos \theta \cos \omega t - A \sin \theta \sin \omega t$$

$$= \operatorname{Re} A e^{j\theta} e^{j\omega t} = \frac{A}{2} e^{j\theta} e^{j\omega t} + \frac{A}{2} e^{-j\theta} e^{-j\omega t}$$

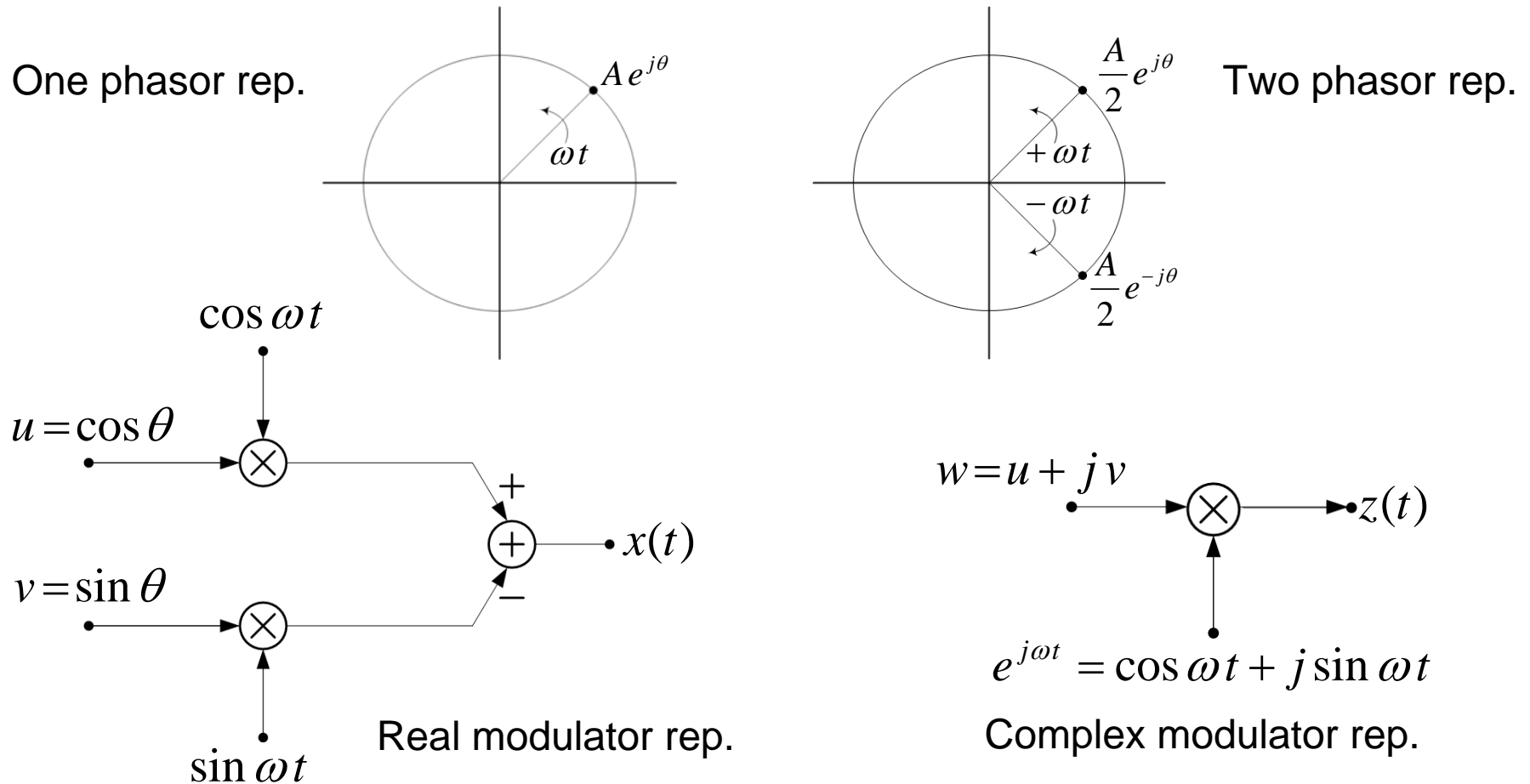

5. **Example 2:** Modulators and Demodulators (ECE 311, 312, 331, 332, 421, 423, 444, 457). Phasors generalize to time varying phasors.

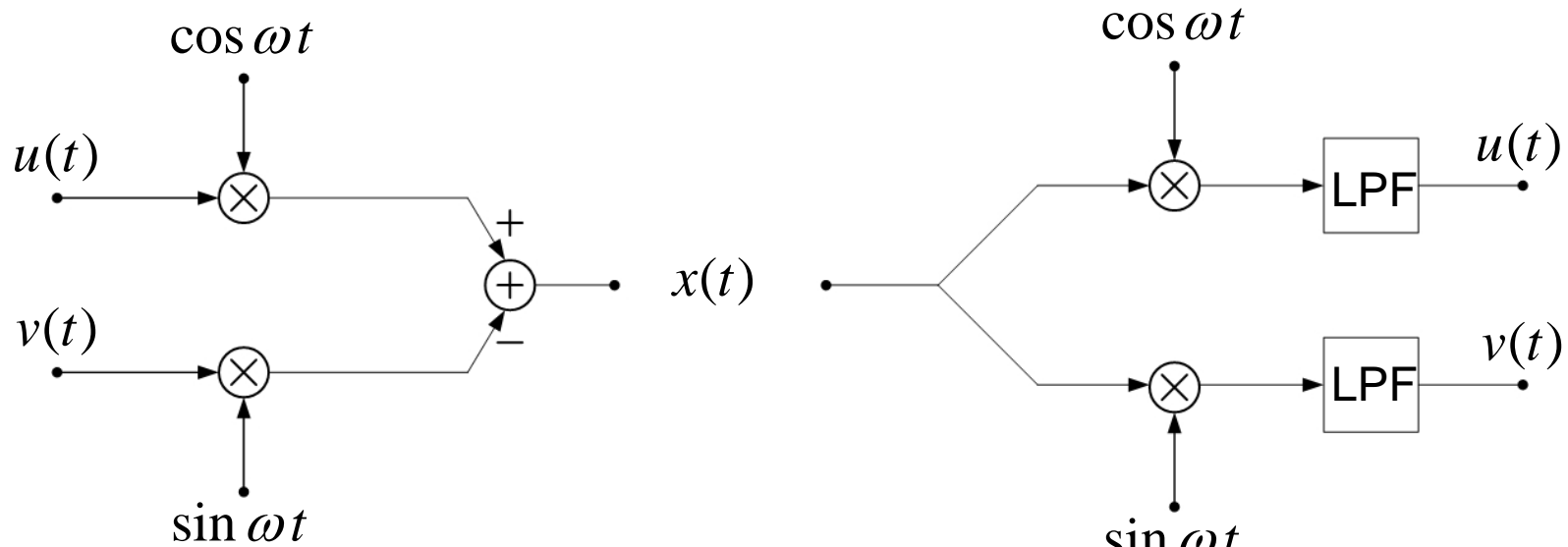

TX: Baseband information-bearing signals, modulated to RF

RX: RF signal demodulated to baseband to recover info.

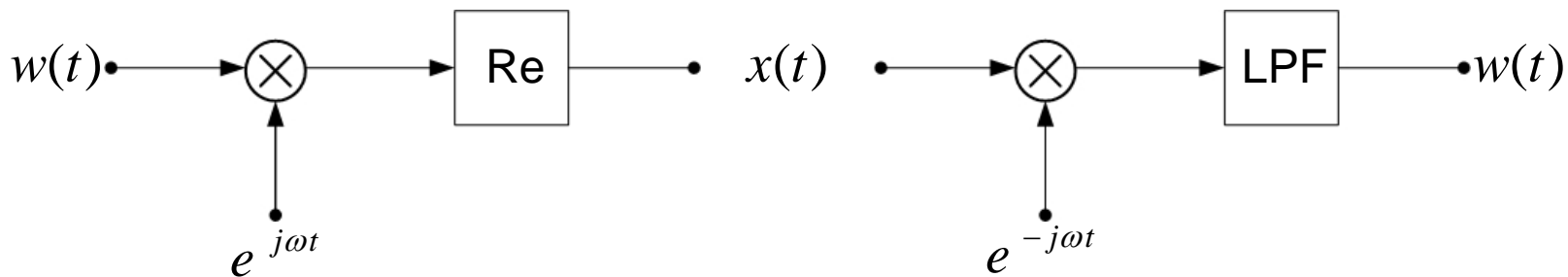

$$w(t) = u(t) + jv(t)$$

Complex mod/demod

$$e^{j\omega t} = \cos \omega t + j \sin \omega t$$

6. **Example 3:** 2-Dimensional Fields and Polarization (ECE 341, 342, 444, 457). Phasors also generalize to mismatched phasors. These produce Lissajous figures, or ellipses.

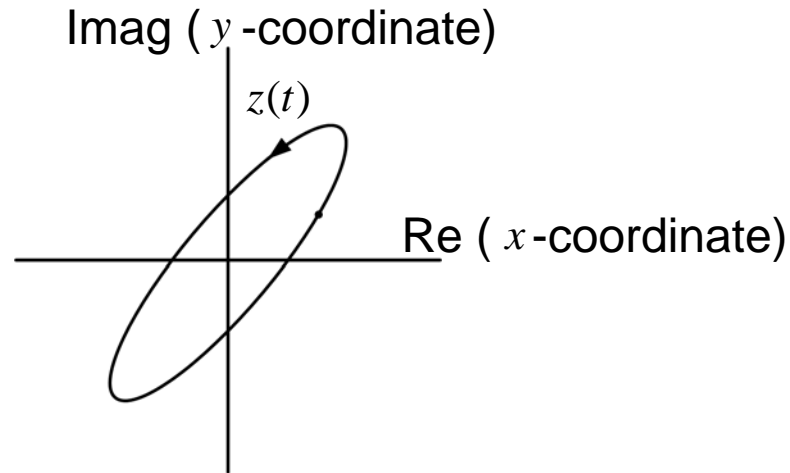

$$\begin{aligned}
 z(t) &= E_x^{(t)} + j E_y^{(t)} = A_x \cos(\omega t + \theta_x) + j A_y \sin(\omega t + \theta_y) \\
 &= \text{Re } A_x e^{j\theta_x} e^{j\omega t} - j \text{Im } A_y e^{-j\theta_y} e^{-j\omega t} \\
 &= B_x e^{j\varphi_x} e^{j\omega t} + B_y e^{j\varphi_y} e^{-j\omega t}
 \end{aligned}$$

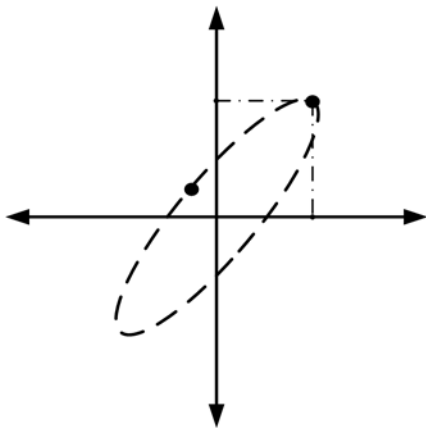

Sum of two linearly polarized fields

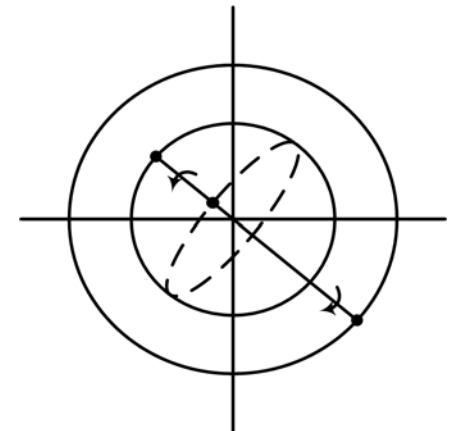

Sum of left and right circularly polarized fields

7. **Example 4**: Filter Design (ECE 202, 311, 312, 331, 332).

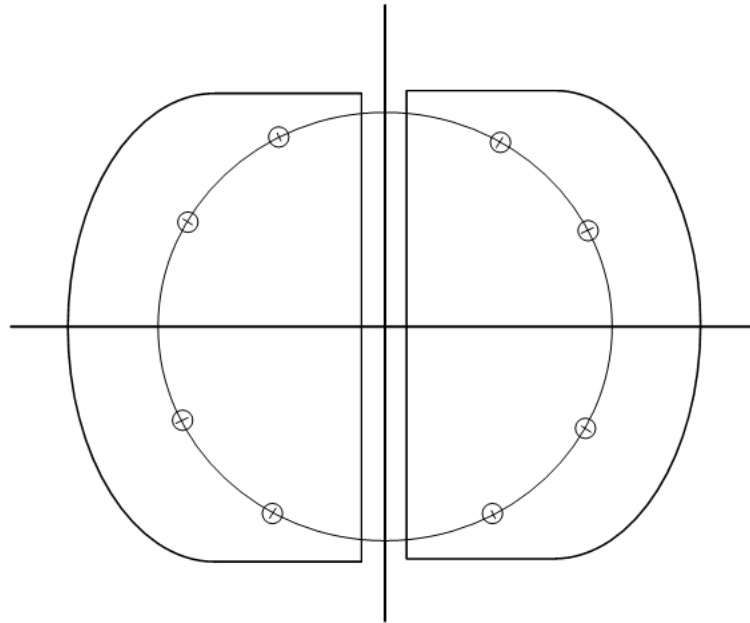

These $2n$ poles will have to be organized into causal stable poles and anti-causal stable poles. This suggests that right-half plane poles are not all bad. More to come.

End of Part 1, demonstrating the power of complex representations for representing real signals and real fields.

PART 2: Polynomials, Roots of Unity, ODEs, and OP-AMPs

1. $s + 1$: Richard Feynman (Nobel QED) liked the equation

$$e^{j\pi} + 1 = 0$$

because it tied together 0, 1, e , j , π . But we know $e^{j\pi}$ is just the single zero of the first order poly $s+1$.

ECEs turn zeros into poles by constructing a *rational* transfer functions:

$$H(s) = \frac{1}{s+1} \leftrightarrow h(t) = e^{-t} u(t)$$

In our circuits and systems courses (ECE 202, 311, 312, 331, 332), we describe filters by the transfer equation $Y(s) = H(s) X(s)$. To say $H(s) = 1/(s+1)$ is to say $(s+1)Y(s) = X(s)$, which is to say $dy(t)/dt + y(t) = x(t)$.

That is, by turning zeros of a polynomial into poles of a transfer function, we construct the coefficients of an ordinary differential equation from the coefficients of a poly. This suggests that good differential equations, or good circuits, should be constructed from good polynomials. Good poles.

2. $s^2 + 1$: Let's inch along to the poly $s^2 + 1$, which is the poly that first forced complex numbers into our lexicon. The corresponding transfer function is

$$H(s) = \frac{1}{s^2 + 1} = \frac{1}{(s + j)(s - j)} = \frac{-1/2j}{s + j} + \frac{1/2j}{s - j}$$

$$\leftrightarrow h(t) = \frac{e^{jt} - e^{-jt}}{2j} = \sin t u(t)$$

This is ECE 202, 311, 312, and M 160, 161, 340. We have various descriptions of this transfer function.

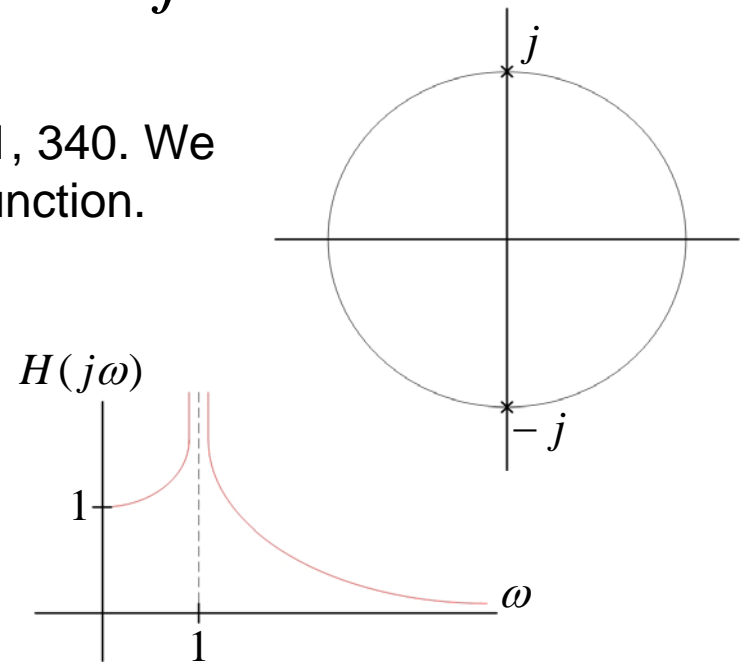
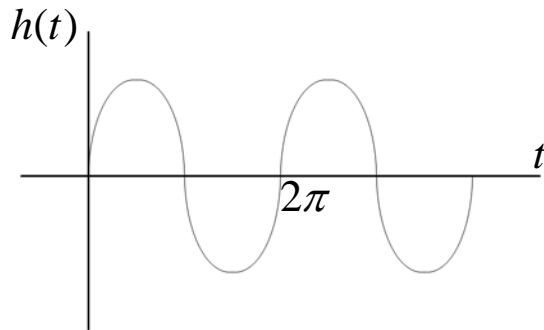

2. $s^2 + 1$ (continued): From the transfer equation, we can derive the ordinary differential equation for this system, steal an analog computer wiring diagram, and design an OP-AMP circuit:

$$Y(s) = H(s) X(s)$$

$$(s^2 + 1)Y(s) = X(s) \leftrightarrow \frac{d^2 y(t)}{dt^2} + y(t) = x(t)$$

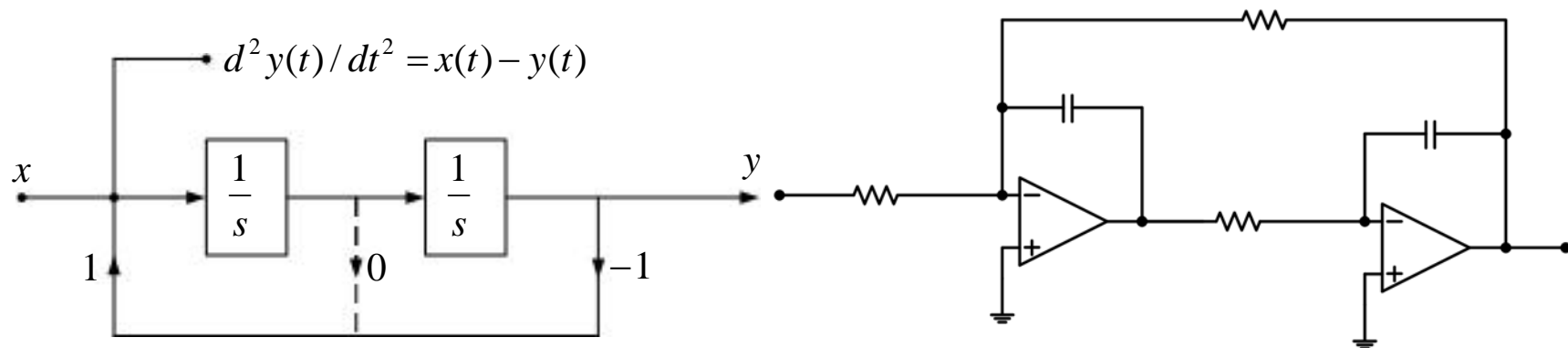

This is the connection between M 160, 161, 340, ECE 202, 311, 312, 331, 332.

2. $s^2 + 1$ (continued): To the circuit designer, the OP-AMP is *the thing*. But to a systems designer, the transfer function is *the thing*.

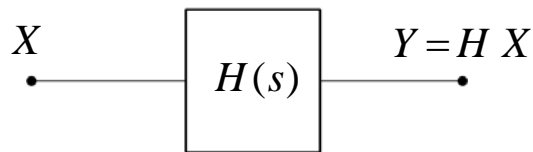
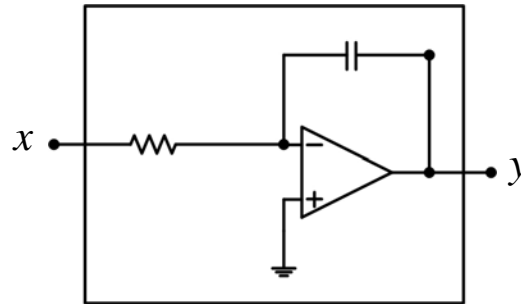

As a poly, $H(s)$ codes for ODE; as a complex impedance, $H(s)$ maps $x(t) = e^{st}$ into $y(t) = H(s) e^{st}$.

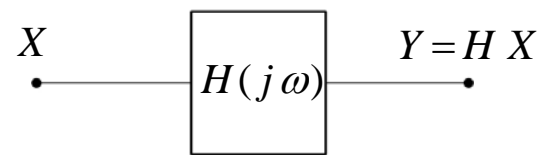

As a complex frequency response, $H(j\omega)$ maps the eigenvector $x(t) = e^{j\omega t}$ into the eigenvector $y(t) = H(j\omega) e^{j\omega t}$, scaled by the eigenvalue $H(j\omega)$.

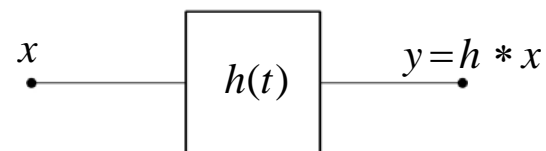

As an impulse response, $h(t)$ maps $x(t)$ into $y(t) = (h * x)(t)$.

Make no mistake: The OP-AMP does it. However, the transfer function describes the ODE obeyed by the OP-AMP. The complex frequency response reveals frequency selectivity by telling us that it is as if we are multiplying frequency components in the frequency domain, and the impulse response explains time domain smoothness by telling us that it is as if we are convolving signals in the time domain.

2. $s^2 + 1$ (continued): In circuits and systems, filtering is done in the time domain, and talked about in the frequency domain. We never actually build $H(j\omega)$. Rather, we build a circuit to meet specifications on $H(j\omega)$. But in coherent optics, we use lenses to Fourier transform inputs, multiply by the spectral mask $H(j\omega)$, to get $Y(j\omega) = H(j\omega) X(j\omega)$, and inverse Fourier transform with another lens to get $y(t)$. That is, in coherent optics, filtering is actually done in the frequency domain, and talked about in time domain. The impulse response $h(t)$ is called the point spread function.

Things can get even fancier in coherent optics, where a prism is used to separate frequency components into space, where frequency domain filtering is applied to construct very short pulses. This ECE 457.

2. $s^2 + 1$ (continued): Where does time domain smoothness come from, and frequency domain selectivity?

Answer: At every time t , $y(t)$ must be so smooth that it, plus its second derivative is zero. Cosines do it. For more general differential equations, linear combinations of damped complex exponentials do it.

At some frequencies, the response of $y(t)$ to an input $x(t) = 1 \cdot e^{j\omega t}$, namely $d^2 y / dt^2 + y = -\omega^2 A e^{j\omega t} + A e^{j\omega t} = 1 \cdot e^{j\omega t}$, has so much destructive interference between these two components that the circuit can support large amplitudes A while meeting the unity input constraint. At these frequencies, the circuit or system has large gain. Conversely,

So, even filtering is, at bottom, an interference effect. Interference is behind everything: focusing in cameras, optical image formation, polarized glasses, radiation patterns in antennas, circuits, control, and communications.

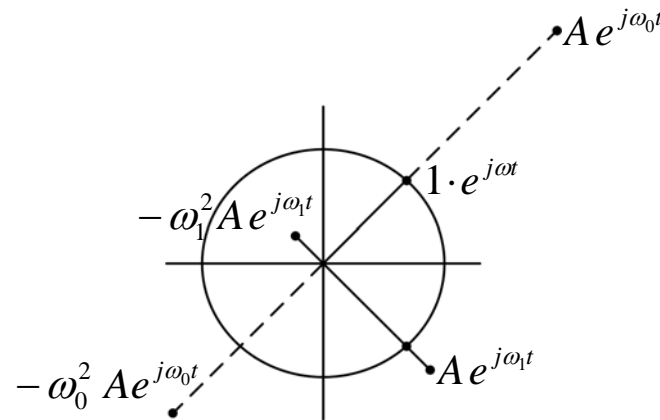

2. $s^2 + 1$ (continued): Are any of these insights useful for systems or channels which do not obey ODEs?

Answer: Yes. We try to model non-rational transfer functions $H(s)$, with rational approximations $G(s)$, as illustrated below:

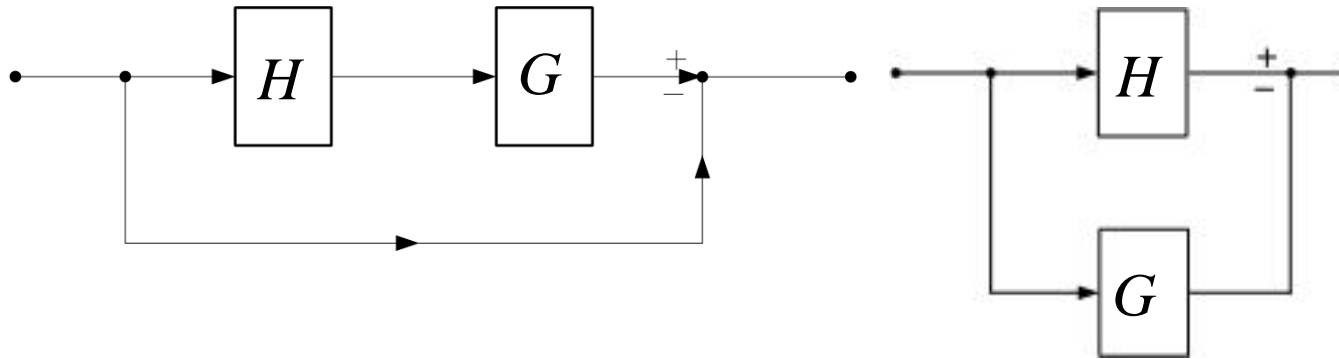

$$HG \approx 1$$

Series: equalizer for communications.
(ECE 311, 312, 421, 423)

$$H \frac{1}{G} \approx 1$$

Parallel: model follower for control. (ECE
311, 312, 411, 412)

3. $s^{2n} + 1$: Let's get reckless. This polynomial has the 2nth roots of -1 for its zeros. These zeros could not be identified without complex analysis.

$$s_k^{2n} = -1, \quad k = 1, 2, \dots, 2n.$$

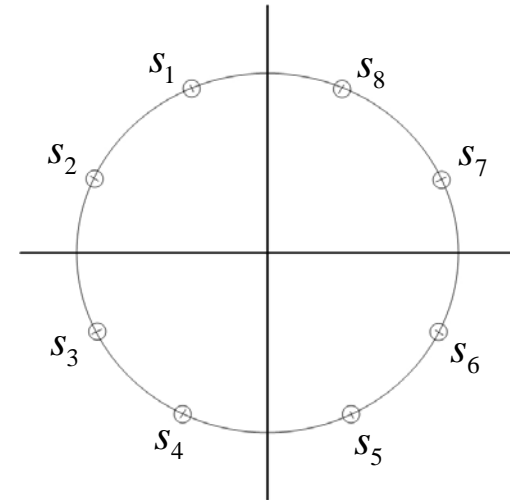

We like the LHP poles as poles of a causal and stable filter $H(s)$. Actually, there is a lot to like about the RHP poles: they are poles of an anti-causal and stable filter. In fact, because of the symmetries, if we use the LHP poles to construct a causal transfer function $H(s)$, the RHP poles will automatically build the anti-causal transfer function $H^*(-s^*)$. This grouping of poles could not be done without complex analysis.

$H(s)$ is the transfer function for a causal D/A or transmit filter in a cell phone and a causal D/A or synthesis filter in a digital controller. $H^*(-s^*)$ is the transfer function for an anti-causal A/D or receive filter in a cell phone and an anti-causal A/D or analysis filter in a digital controller. Every cell phone and every digital controller wishes it could have a non-causal A/D.

3. $s^{2n} + 1$ (continued) : Let's construct the transfer function $H(s)$ from the LHP poles, and use the complex symmetry of the poles to factor $H(s)$ into two second order sections:

$$H(s) = H_1(s) H_2(s) = \frac{1}{s^2 - 2\zeta_1 s + 1} \frac{1}{s^2 - 2\zeta_2 s + 1}$$

This factoring could not be done without complex analysis.

Each of the transfer functions codes for an ODE:

$$(s^2 - 2\zeta_1 s + 1)Y(s) = X(s) \leftrightarrow d^2 y(t) / dt^2 - 2\zeta_1 dy(t) / dt + y(t) = x(t)$$

Each ODE codes for an analog computer wiring diagram:

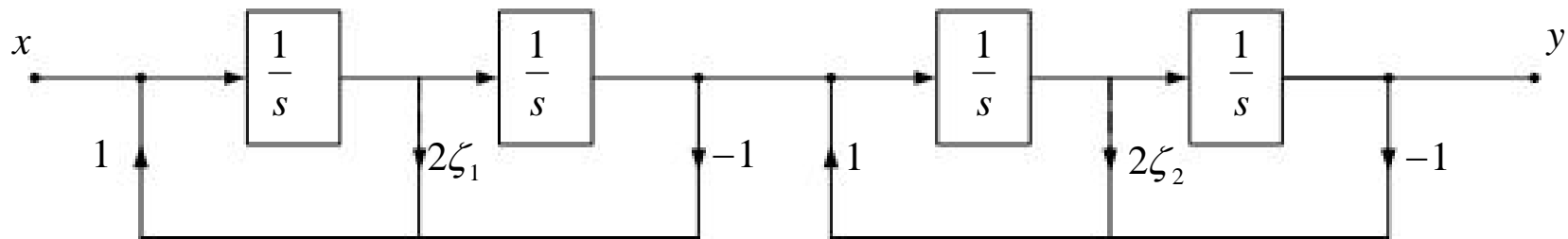

This analog computer wiring diagram should code for an OP-AMP circuit.
This is ECE 311, 312, 331, 332.

3. $s^{2n} + 1$ (continued) : Let's redraw the analog computer wiring diagram:

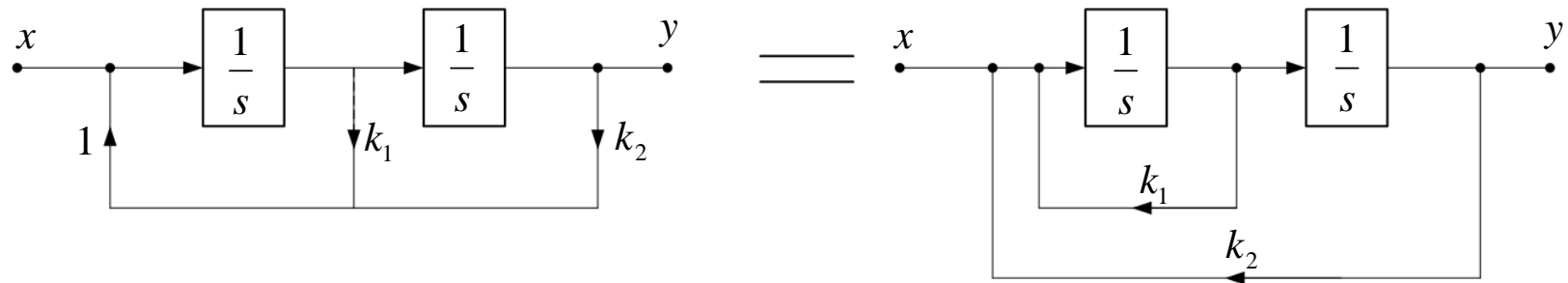

This is feedback. ECE 311, 312, 331, 332, 411, 412. Let's build it up, from scratch.

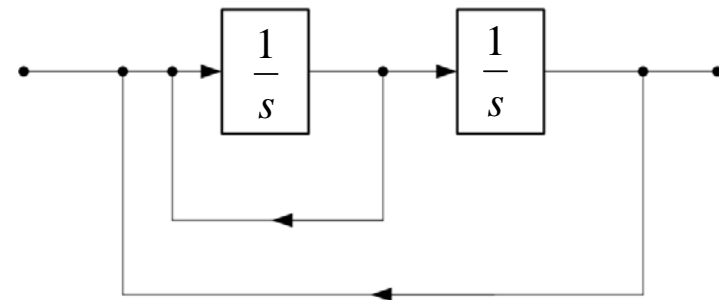
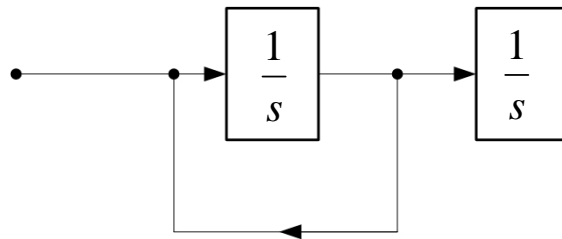
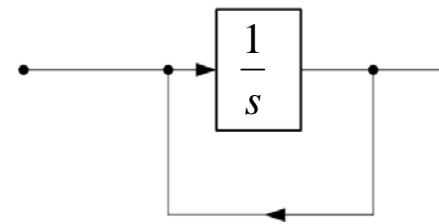
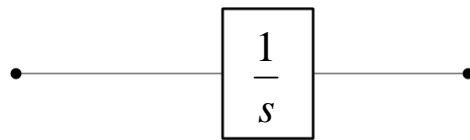

3. $s^{2n} + 1$ (continued) : Let's identify an OP-AMP circuit with each of these successively more complicated feedback diagrams. We are done.

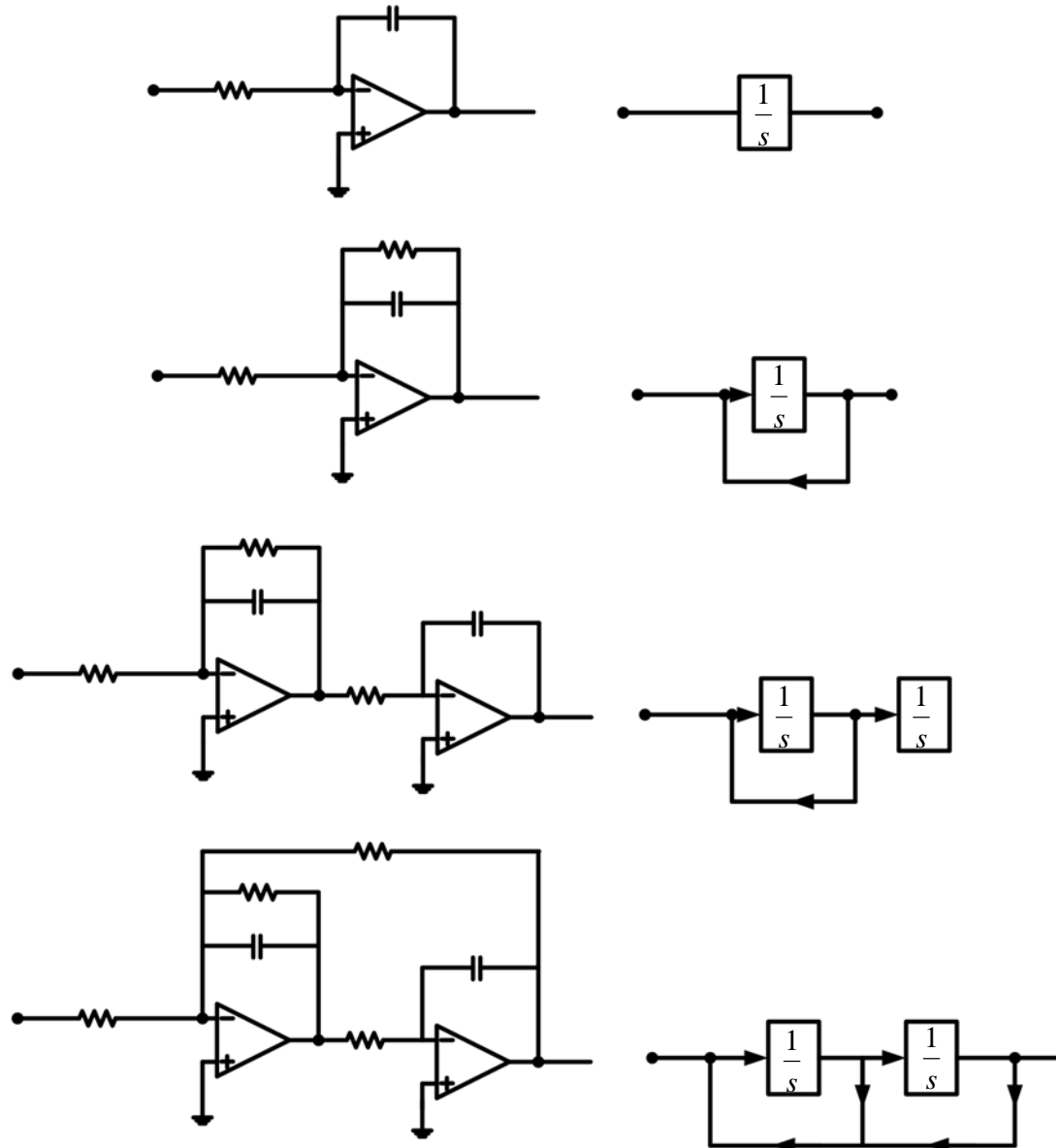

4. Summary :

- Single complex channels code for dual real channels, thereby clarifying our understanding of modulation and polarization.
- Roots of unity code for a transfer function.
- This transfer function may be factored into its causal and anti-causal parts.
- The causal part codes for an ODE.
- This ODE codes for an analog computer wiring diagram.
- This analog computer wiring diagram codes for an OP-AMP circuit.
- Good OP-AMP circuits come from good polynomials.
- You name the effect you are after and I will argue for interference effects as the underlying basis for what you can achieve.
- Interference effects are revealed by phasors.
- In rational systems of RLC and OP-AMPs, these interference effects are determined by polynomials.