

# *Underwater Target Detection & Classification from Disparate Sonar Platforms*

**People:** [Prof. Mahmood R. Azimi](mailto:azimi@engr.colostate.edu), Project Leader, e-mail: [azimi@engr.colostate.edu](mailto:azimi@engr.colostate.edu)  
J. Derek Tucker, Ph.D. Student, e-mail: [dtucker@engr.colostate.edu](mailto:dtucker@engr.colostate.edu)  
Nick Klausner, M.S. Student, e-mail: [nklausne@engr.colostate.edu](mailto:nklausne@engr.colostate.edu)

**Sponsor:** Office of Naval Research

## **Problem & Objectives of the Research:**

A critical need of the U.S. Navy is the development of a reliable, efficient and robust underwater target detection and classification system that can operate with multiple disparate sensor systems. In a surveillance area there could be multiple Unmanned Underwater Vehicles (UUV's) each equipped with a wide variety of sensors including different types of sonar, magnetic, or electro-optical systems. Preliminary detection, feature extraction and object classification can be performed based upon the data collected using every sensory system on one or multiple vehicles. A final decision-making usually takes place at the central station using some type of a decision-level or a feature-level fusion. However, decision-making based upon individual sensory data typically leads to incomplete, degraded or biased decisions hence resulting in an unacceptable final detection and classification performance at the fusion center.

To allow collaborative decision-making among several sonar or other sensor platforms, it is essential to detect and further scrutinize the information-bearing parts of the data collected by various sensory systems. This involves detecting, isolating and representing, in terms of some pertinent attributes, the *coherent* information among the multiple data sets. This is an extremely challenging problem due to disparate nature of the problem. Thus, to develop such a system-level solution, new methodologies are needed to: (a) collaboratively detect and agree on threats occurring within the field of view of the sensors, (b) perform collaborative feature extraction to capture common target attributes from multiple sensor platforms, (c) perform object classification and identification, (g) and finally develop a single integrated target assessment picture based upon the detected, localized and classified targets from multiple disparate sensors.

The goal of this research is to develop a novel framework for multi-sensor coherence analysis that can be applied to the data collected using multiple (two or more) disparate sonar systems. Using the proposed methods allows for simultaneous detection and feature extraction of coherent target information among multiple sonar images. Our *detection hypothesis* in this multi-sensor coherence analysis is that presence of objects in the multi-platform sonar data leads to high level of coherence measure comparing to that of the background clutter. The coherence pattern extracted from each object allows for classification of the detected objects (*classification hypothesis*). A subset of coherent-based features that capture high discriminatory information can then be applied to a classifier to separate target and non-target objects.

## **Results:**

The data set for our study is a multi-platform sonar database of images collected by the Naval Warfare Surface Center (NSWC) at Panama City, Florida. The data set contains a high frequency (HF) high resolution sonar image over the target field and three broadband (BB) sonar images co-registered over

the same region. The targets were implanted in various background and clutter densities and vary in size and clarity in the sonar images.

Figure 1 shows the developed system using two coherent-based detectors with a simple detection score fusion. As can be seen, the first detector uses one HF image and one BB image with a different spatial resolution, while the second detector uses that same BB image and a second BB image with different frequency characteristics. It is interesting to note, in the first detector, coherence information in the two BB sonar images is exploited to further suppress clutter ROI's and detect potential targets, the coherence information in the second detector solidifies the decision in the first detector by verifying the joint presence in the HF and BB images. Figures 2(a) and (b) show the line plots of the canonical correlations [1]-[5] over targets and non-targets in a 72 X 12 and 24 X 224 regions of interest (ROI) for the HF and BB images, respectively. There is a noticeable separation of the canonical correlations between the Targets and Non Targets for both pair of sensors.

The system is then implemented on the entire NSWC multi-platform sonar imagery data. The receiver operating characteristics (ROC) curves (plots of probability of detection,  $P_d$ , versus probability of false alarm,  $P_{fa}$ ) for the individual detectors and the fusion of the two are presented in Figure 3. At the knee point (where  $P_d + P_{fa} = 1$ ) of ROC for the HF-BB<sub>1</sub> detector we have  $P_d = 92\%$  and  $P_{fa} = 8\%$ . While for the BB<sub>1</sub>-BB<sub>2</sub> detector the knee point exhibits  $P_d = 93\%$  and  $P_{fa} = 7\%$ . After the fusion of the two detectors, the knee point of the fused ROC gives  $P_d = 99\%$  and  $P_{fa} = 1\%$ , which demonstrates excellent overall detection performance of the proposed coherence-based detection system.

#### **Recent Publications:**

[1] J. D. Tucker, M. R. Azimi-Sadjadi, and G. J. Dobeck, "Coherent-based method for detection of underwater objects from sonar imagery," Proc. SPIE, vol. 6553, pp. 65530U1–65520U8, April 2007.

[2] J. D. Tucker, M. R. Azimi-Sadjadi, and G. J. Dobeck, "Canonical coordinates for detection and classification of underwater objects from sonar imagery," Proc. of IEEE OCEANS 2007 Conference Europe, pp. 1–6, June 2007.

[3] J. D. Tucker, M. R. Azimi-Sadjadi, Target Detection from Dual Disparate Sonar Platforms Using Canonical Correlations, Proc. SPIE, vol. 6553, pp. 65530U-65520U8, March 2008

[4] J. D. Tucker, N. Klausner, M. R. Azimi-Sadjadi, "Target Detection in M-Disparate Sonar Platforms using Multichannel Hypothesis Testing." Proc. IEEE/MTS Oceans 2008, to be published, September 2008

[5] J. D. Tucker and M. R. Azimi-Sadjadi, "Coherence-based Underwater Target Detection and Classification for Side-Scan Sonar Imagery." Sea Technology Magazine, vol. 49, no. 12, pp 10-14, December 2008

#### **Acknowledgment:**

The data used in this work were supplied by NSWC-Panama City under the auspices of the Office of Naval Research, Code 321 Undersea Signal Processing.

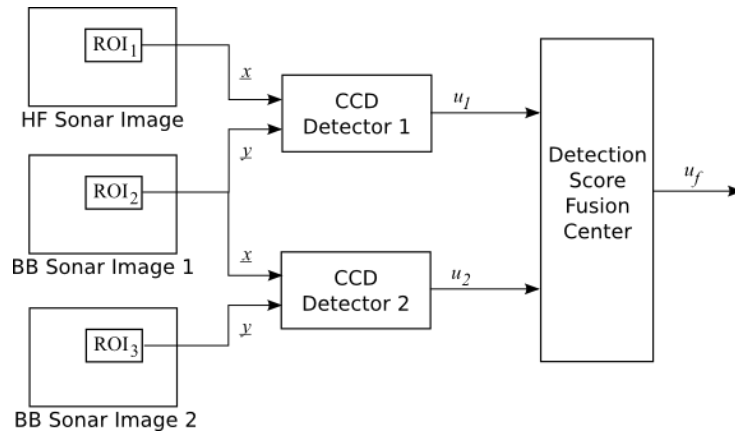

Figure 1. Block diagram of the Multi-platform Detection System.

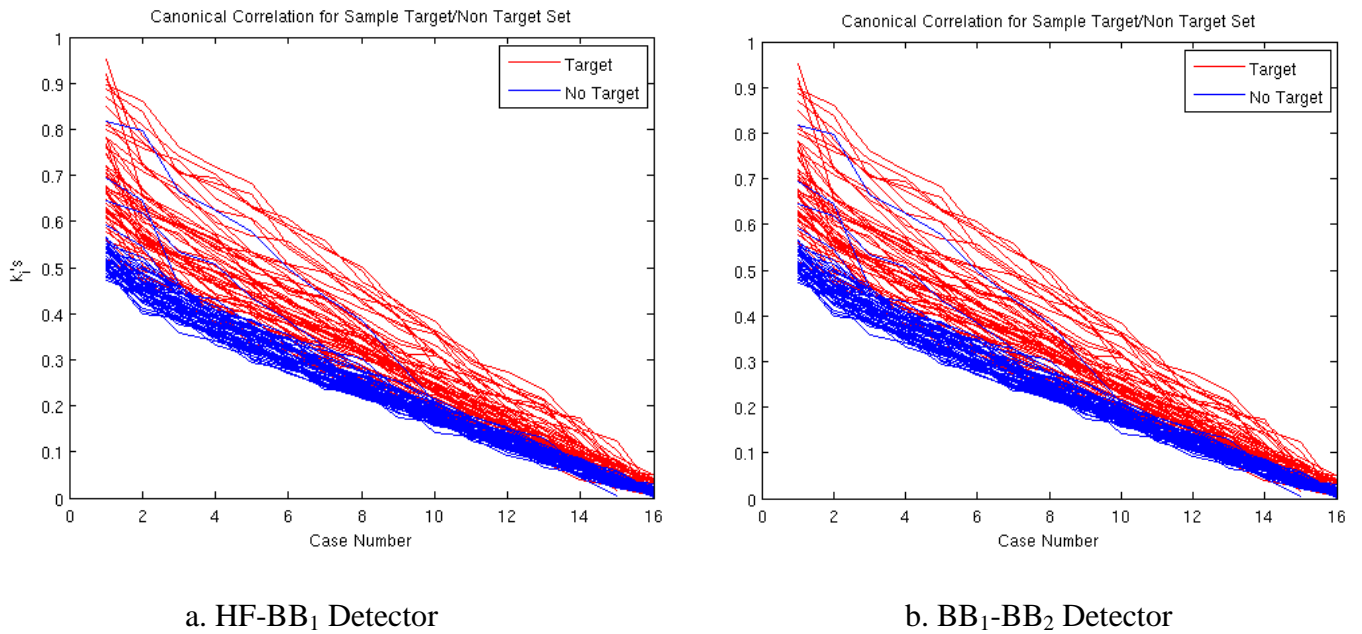

Figure 2. Plot of Canonical Correlations for Target and Background for Both Detectors

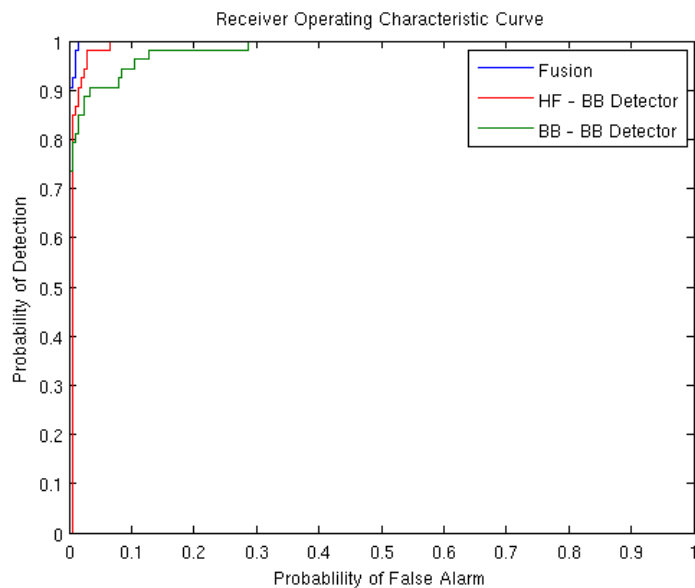

Figure 3. ROC Curves for the Individual Detectors and the Fused System.