

## 5.4. Various flow meters

### 5.4.1. Venturi flow meter

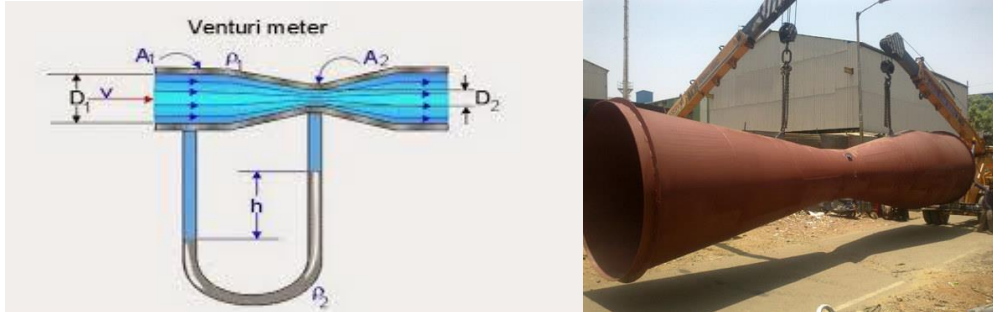

### 5.4.2. Nozzle flow meter

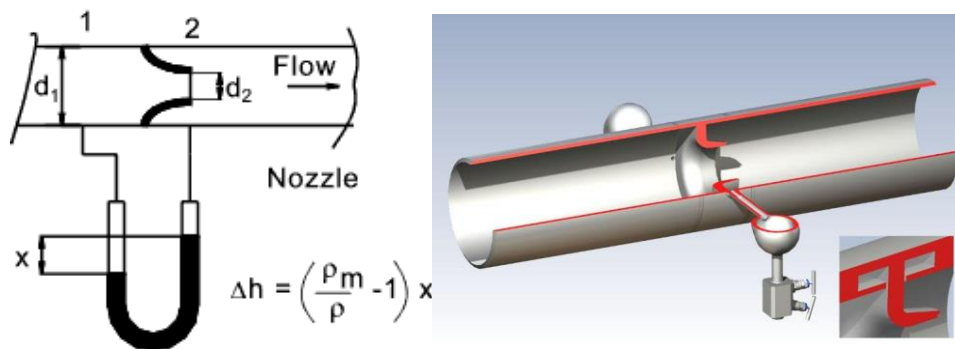

### 5.4.3. Coriolis flow meter

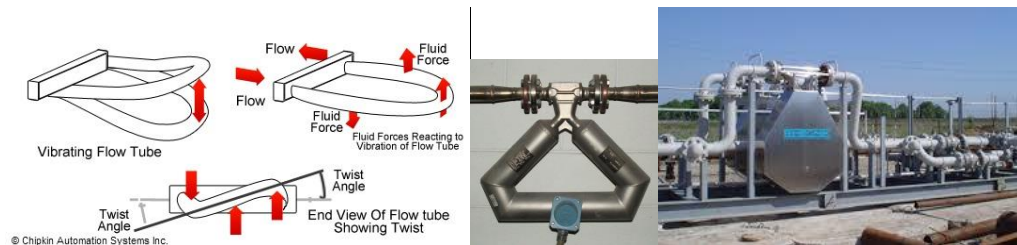

### 5.4.4. Turbine flow meter

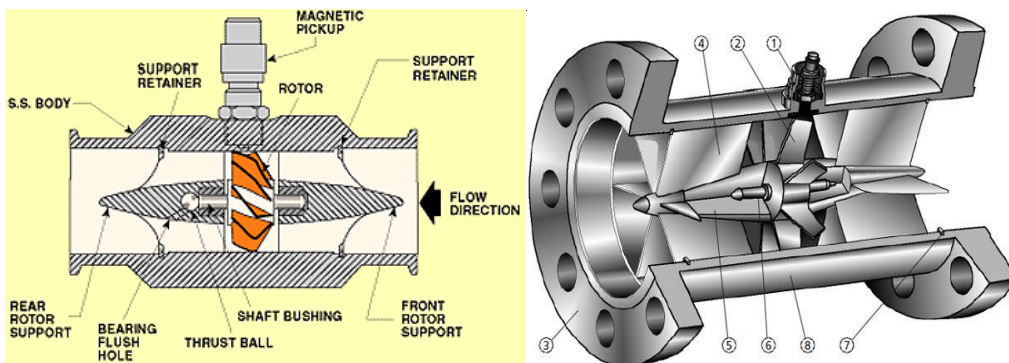

### 5.4.5. Propeller flow meter

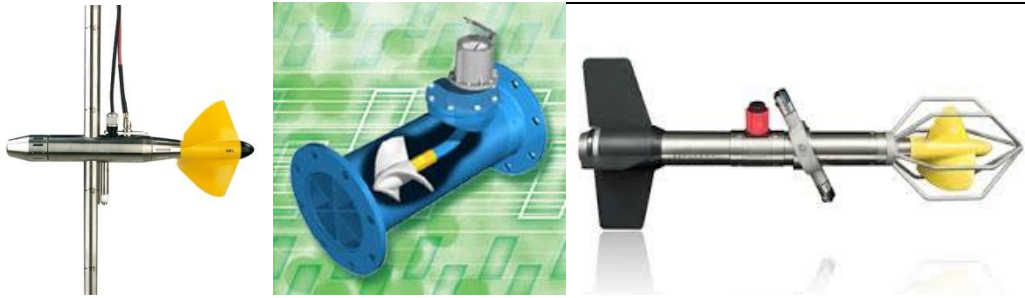

### 5.4.6. Price current meter

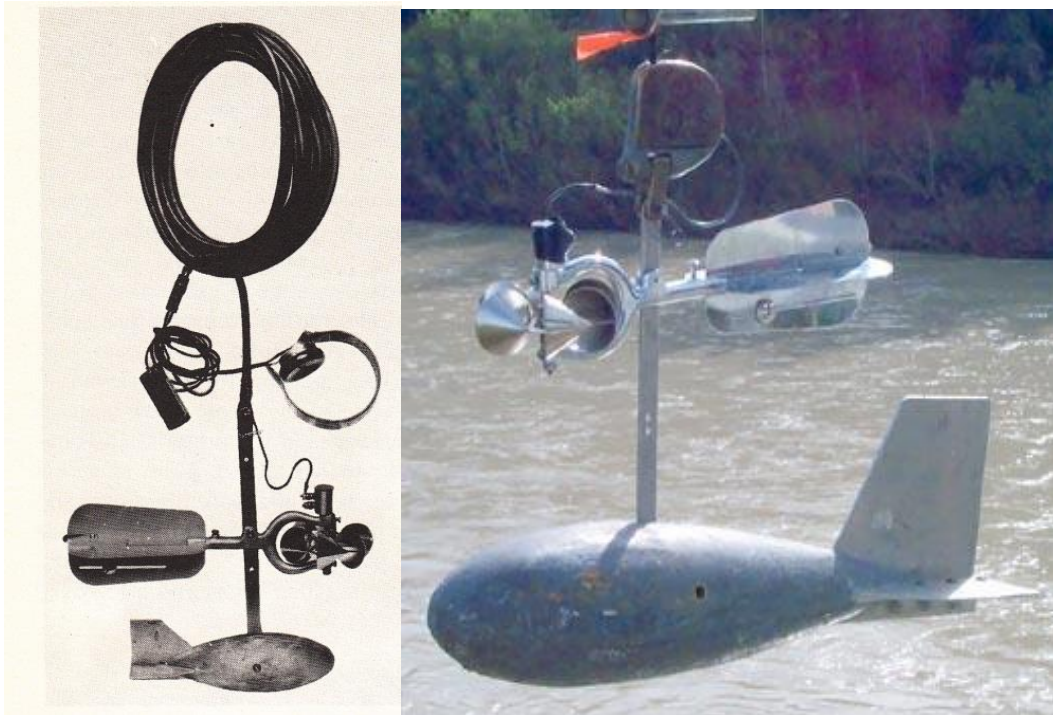

### 5.4.7. Ultrasonic flow meter

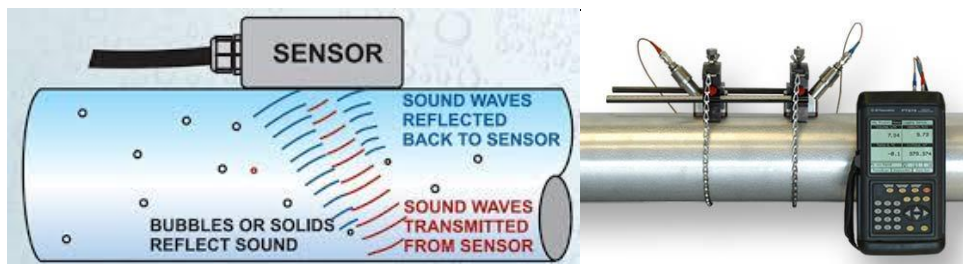

### 5.4.8. Acoustic Doppler Current Profiler (ADCP)

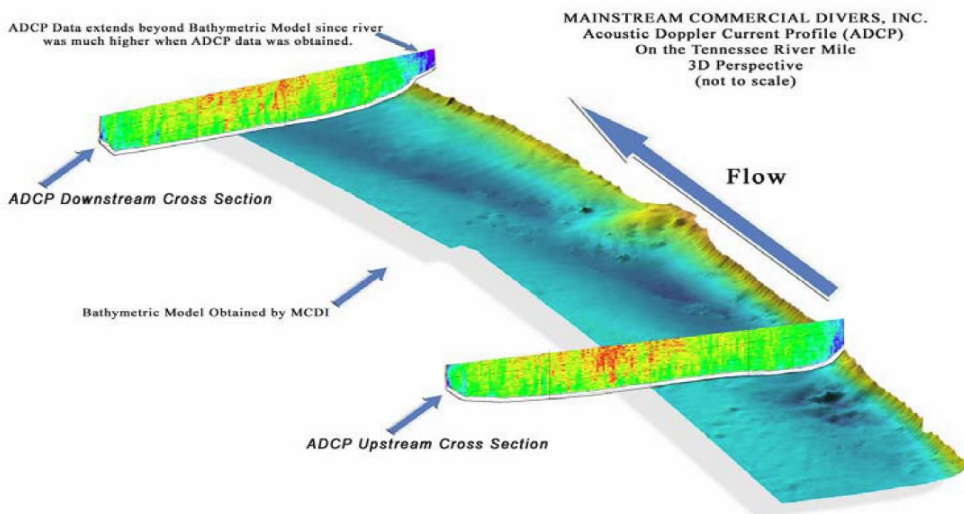
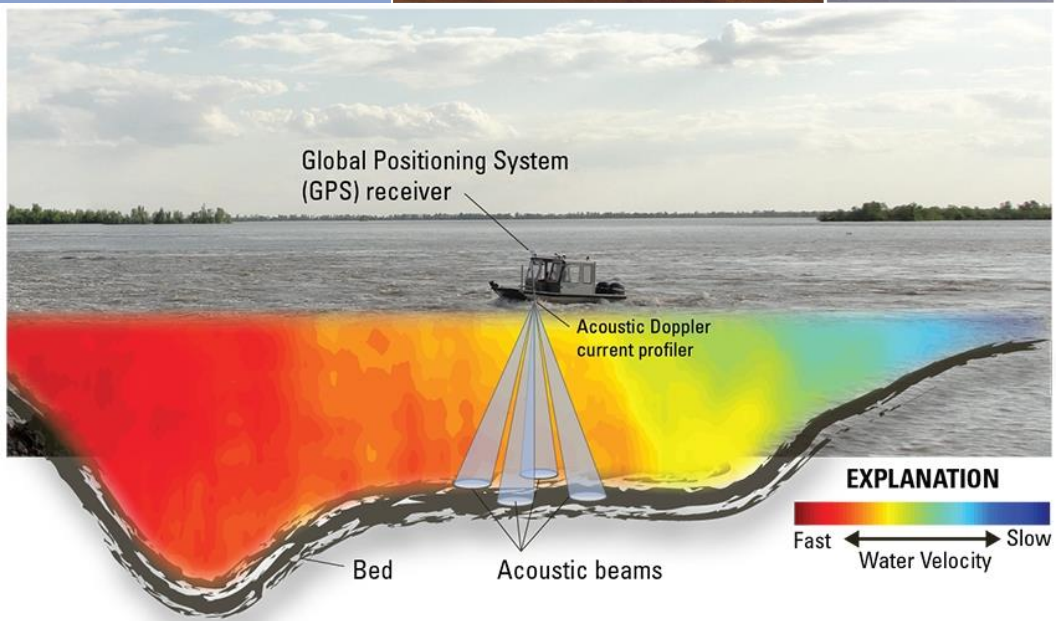
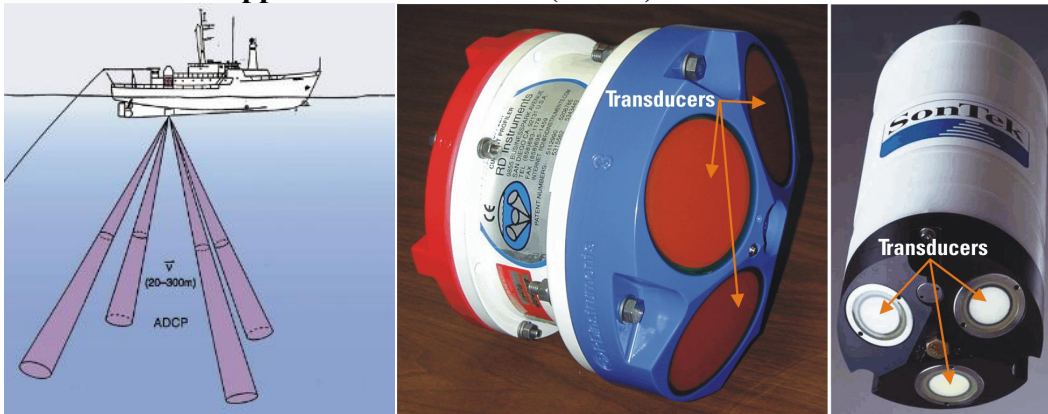

### 5.4.9. Magnetic flowmeter

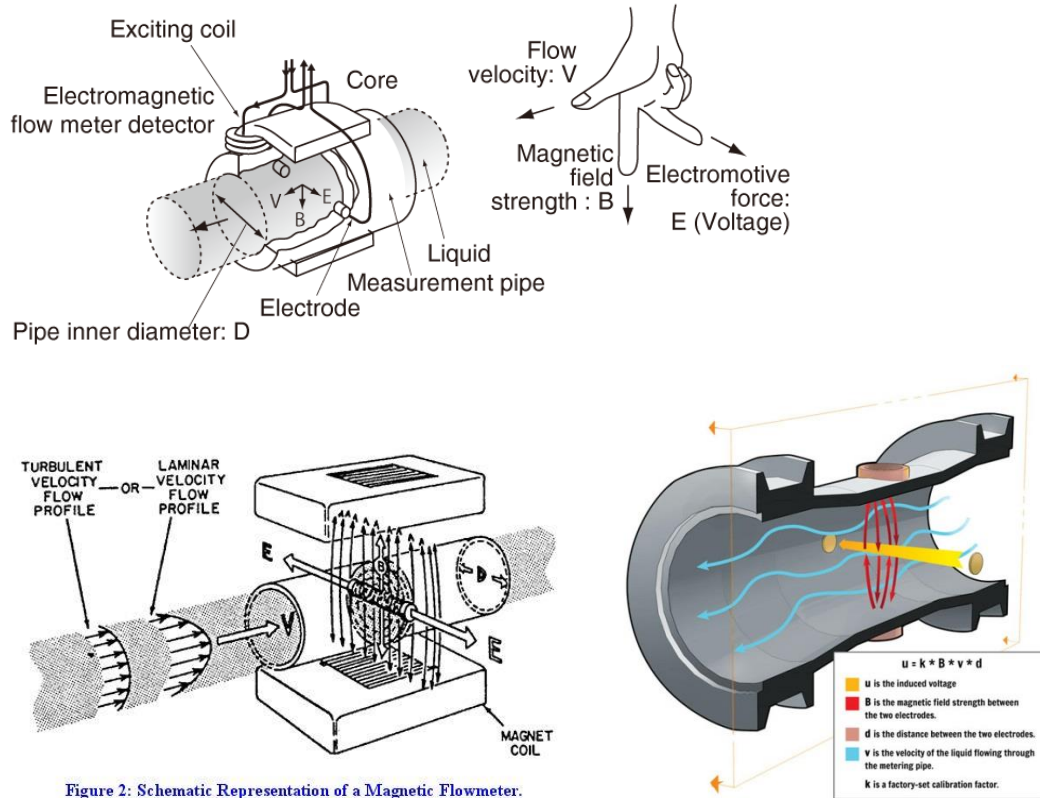

Figure 2: Schematic Representation of a Magnetic Flowmeter.

### 5.4.10. Laser Doppler Velocimeter

